

POLYRAD®

Rail & Transit

WIRE AND CABLE



TRANSIT



POLYRAD®

Servicing the Rail & Transit Markets

This catalog contains in-depth information on the most comprehensive line of rail & transit wire and cable available today. It features the latest information on products, along with detailed technical and specification data in indexed sections — with an easy-to-use “spec-on-a-page” format.

The “spec-on-a-page” format was developed to meet your needs. It features up-to-the-minute product information, from applications and constructions to detailed technical and specification data. There’s also a technical information section for additional assistance.

And, of course, if you need any further data, General Cable’s Customer Service staff provides the answers you need quickly and efficiently.



All information in this catalog is presented solely as a guide to product selection and is believed to be reliable. All printing errors are subject to correction in subsequent releases of this catalog. Although General Cable has taken precautions to ensure the accuracy of the product specifications at the time of publication, the specifications of all products contained herein are subject to change without notice.

GENERAL CABLE, CAROL, CAROLGRENE, DURALOX, FREP, POLYRAD, VNTC, ULTRA FLEX, UNIBLEND and UNISHIELD are trademarks of General Cable Technologies Corporation.

© 2019. General Cable Technologies Corporation.
Highland Heights, KY 41076
All rights reserved. Printed in USA.

What's New?



IRIS CERTIFICATION™ REV. 03 — THE NEW GLOBAL STANDARD FOR QUALITY MANAGEMENT SYSTEMS IN THE RAILWAY SECTOR

General Cable is the first North American wire & cable manufacturer to receive the distinguished IRIS CERTIFICATION™ REV. 03 and ISO 9001:2015, meeting the new global standards for quality management systems in the railway sector. Through successful certifications such as these and partnerships with leading industry OEMs, we will continue delivering results and value by responding to an ever-changing set of customer expectations and market conditions. Ask your sales representative today what doing business with an ISO TS 22163/IRIS REV 3.0 CERTIFIED partner means to you!

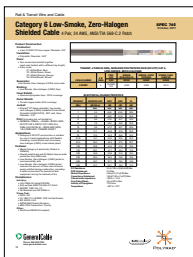

NOW OFFERING UL SAFETY LISTED NFPA 130 DATA COMMUNICATIONS CABLES

The NFPA 130 standard requires wire and cable to meet the Underwriters Labs (UL) 1685 flame test (UL 1685 flame method is per IEEE 1202/FT4) and is largely focused on two aspects of safety: flame spread and smoke generation. The main purpose of the standard is to set limits to the spread of flame. It is also to set limits on the amount of smoke generated by the wire and cable once it comes into contact with a fire. The ability of the occupants of a vehicle to escape a fire event increases significantly by setting these limits. General Cable now offers a line of Low-Smoke, Zero-Halogen (LSZH) data communications Category 5e and 6 cables. See pages 10-12 for the latest information on these products, along with detailed technical and specification data.



CHARGING FORWARD WITH PORTABLE POWER FOR HYBRID & ELECTRIC VEHICLES

General Cable's line of Carol® Brand CarolGreene™ Ultra Flex® EV cables supplies charging power for all electric vehicles on the market today and is compatible with commercial and residential charging applications. The CarolGreene EV line, when terminated in accordance with electric vehicle industry standards, is the most comprehensive product offering, with three standard jacket types: CarolGreene EV all-rubber jacket, CarolGreene EVE Thermoplastic Elastomer (TPE) jacket, and CarolGreene EVT Polyvinylchloride (PVC) jacket.



TRANSPORTATION PRODUCTS

For more than a century, General Cable has been designing and manufacturing reliable solutions for OEMs and aftermarket customers built on quality. We manufacture products from battery cable, bulk ignition wire, primary wire and Electric Vehicle (EV) products to custom wire, cable and simple to complex harness assemblies. General Cable is the answer for Original Equipment Manufacturers (OEM) and Suppliers (OES), Tier I and Tier II suppliers and OEM distribution customers.

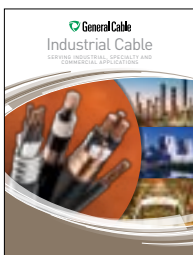

INDUSTRIAL CABLES

General Cable's line of industrial cables serves industrial, specialty and commercial applications. When you specify General Cable, not only are you assured of product excellence from legacy cables such as Uniblend®, FREP® and VNTC®, but you also have access to the most extensive line of high-quality industrial cables available anywhere in the industry.

General Cable – Your Rail & Transit Partner

For rapid transit and locomotive applications, General Cable provides the toughest cables to meet the most demanding requirements for long-term performance and reliability. As an industry leader in a challenging marketplace, General Cable has the expertise, facilities and structure to deliver results:

- Leadership in Material Development
- Dedicated Engineering Expertise
- ISO 9001 Quality Assurance Program
- Polyrad® XT - the trusted name in rail & transit wire and cable

A Wide Range of Products

- Car/Locomotive Wiring
- Power Cables
- Control Cables
- Instrumentation Cables
- Coupler Cables
- Electronically Controlled Pneumatic Brake (ECP) Cables
- Data Communications Cables
- Diesel-Electric Locomotive (DLO) Cables
- Head-End Power Cables
- HVAC System Cables
- Off-Road Equipment Cables
- Category Cables

Major End-Users Supplied

- Original Equipment Manufacturers (OEM)
 - Car Builders & Rebuilders
 - Locomotive Builders & Rebuilders
- Transit Agencies
- Distributors
- Subcontractors and Contract Manufacturing to Original Equipment Manufacturers (OEM)
- System Integrators



General Cable's Willimantic, Connecticut plant is one of the most diverse manufacturing facilities of its kind. More than 600,000 square feet of modern manufacturing space is dedicated to design, development, engineering and manufacturing, as well as a wide range of in-house testing and technical support. General Cable's Industrial & Specialty facility has the expertise to design and develop an extensive variety of materials into thousands of cable constructions for sustained and continuous operations in challenging environments. Focused on providing outstanding quality, service and technical support on behalf of our customers, General Cable is the best partner for current and next-generation transit cabling systems.

Quality is Number One

General Cable is always committed to exceeding our customers' expectations for quality and performance. We strive to ensure quality through extensive in-house and third-party testing with strict adherence to specifications and industry standards, as demonstrated by the following certifications and compliances.



IRIS Certification

General Cable is committed to meeting the global approvals and standards of the transit industry and is the only transit cable supplier in North America to be both ISO 9001:2015 and IRIS* Certified. This certification is now tied directly to ISO 9001:2015 under TS 22163, making it a dual rating. UNIFE, the Association of the European Rail Industry, was created in 1991 in anticipation of the creation of the European Union. In 2005, UNIFE established IRIS (International Railway Industry Standard) with the goal of securing higher quality in the railway industry. This recognized industry certification enables railway component suppliers to meet globally recognized levels of quality for their railway components. General Cable's IRIS Certification ensures improved product quality and efficient procedures throughout the whole supply chain.



ISO 9001/2015 Compliance

ISO 9001 is the world's most established quality framework to demonstrate the ability to consistently provide product that meets applicable requirements and enhances customer satisfaction through processes that ensure quality. General Cable is the only wire and cable company in North America to be both ISO 9001:2015 and IRIS Certified.

UL and CSA Approved Laboratories

General Cable's North American (Willimantic, Connecticut U.S.A.) facility has a laboratory quality system based on ISO/IEC 17025:2005, encompassing proper test equipment, test environment, personnel qualifications, test standards and procedures, and data recording and reporting procedures. Accordingly, the Willimantic lab is approved by Underwriters Laboratories (UL) as a testing facility. In fact, the facility is audited and approved by UL for their Client Test Data Program (CTDP), demonstrating a level of performance that does not require UL to witness on-site testing. UL assesses the lab's quality systems and testing methods on an annual basis.

The Willimantic lab is also approved by CSA International (CSA). The CSA Category Program Certification (CPC) is based on ISO/IEC 17025:2005, which provides more repeatable and reliable test results to bring innovative products to market quicker. The General Cable Willimantic, Connecticut facility is certified by CSA to conduct our own testing in a product category. CSA certification requires General Cable to have thorough knowledge of the applicable product standards, access to suitable test facilities and a demonstrated ability to design, manufacture and test products that consistently comply with the standards.



* IRIS Certifications are for Product Category 12, Cabling and Cabinets (design, development and production of electric special cables [power and instrumentation] for the railway industry).

Quality is not something that is achieved and then forgotten but something that we work to improve every day by continuously focusing on design, technology and control. Improved product designs and investment in people and equipment are all part of our quality commitment to you.

**General Cable
North America**

POWERING YOUR MASS TRANSIT

CABLING CONNECTIONS



As developments in the transit industry continue to increase the demand for safety, instantaneous response to commands and the significant reduction of braking distances at higher speeds, General Cable continues to respond with the latest engineered designs.

General Cable's years of dedicated material development, engineering expertise and advanced manufacturing processes were called upon by the transit industry to engineer Electronically Controlled Pneumatic (ECP) brake cables that would meet the stringent standards of AAR S-4210 and be designed specifically for installation both under and between cars.

General Cable's ECP brake cables are the chosen solution for demanding environments, thanks to an engineered construction.

- Unique insulation system utilizing 125°C thermosetting polyolefin cross-linked compound for high-temperature areas
- The reduction of EMI/RFI interference with a tinned copper braided shield
- Arctic-grade, heavy-duty reinforced Cross-linked Chlorinated Polyethylene jacket that provides excellent low-temperature performance and tough mechanical properties
- Optional galvanized or aluminum armor over the cable jacket allows for conduit-free installations, providing significant installed cost savings



 **General Cable**

www.generalcable.com

General Cable ... Powering Your Mass Transit Cabling Connection.

PRODUCT SELECTION LOCATOR

SECTION		PAGES
1	Polyrad® XT, Polyrad® ULTRA and Polyrad® XT-TX Wire and Cable Products	1-8
2	Transit Data Communications Cables	9-13
3	Transit Specialty Cables	14-17
4	Technical Information	18-30

Serving the Rail & Transit Markets

TABLE OF CONTENTS

Section 1		Polyrad® XT, Polyrad® ULTRA and Polyrad® XT-TX Wire and Cable Products	1-8
SPECIFICATION NUMBER	PRODUCT DESCRIPTION	REVISION DATE	PAGE NUMBER
700	Polyrad® XT Flexible Wire and Cable 600 V, Single Conductor, Dual Rated – 125°C/110°C	Nov. 2018	2
705	Polyrad® XT Flexible Wire and Cable 2000 V, Single Conductor, Dual Rated – 125°C/110°C	Nov. 2018	3
710	Polyrad® XT Multi-Conductor Cable 600 V, 125°C, Shielded	Nov. 2018	4
715	Polyrad® ULTRA Wire 600 V, Single Conductor, 125°C, Reduced Weight, Smaller Diameter, Dual Wall	Nov. 2018	5
720	Polyrad® ULTRA Multi-Conductor Cable 600 V, 125°C, Shielded	Nov. 2018	6
725	Polyrad® XT-TX Flexible Wire and Cable 600 V, Single Conductor, NYCT Type TX	Feb. 2019	7
730	Polyrad® XT-TX Flexible Wire and Cable 2000 V, Single Conductor, NYCT Type TX	Feb. 2019	8
Section 2		Transit Data Communications Cables	9-13
SPECIFICATION NUMBER	PRODUCT DESCRIPTION	REVISION DATE	PAGE NUMBER
735	Category 5e Low-Smoke, Zero-Halogen Shielded Cable 4 Pair, 24 AWG, ANSI/TIA 568-C.2 Patch	Nov. 2018	10
740	Category 5e Quad Low-Smoke, Zero-Halogen Shielded Cable 2 Pair, 22 AWG, ANSI/TIA 568-C.2 Patch	Nov. 2018	11
745	Category 6 Low-Smoke, Zero-Halogen Shielded Cable 4 Pair, 24 AWG, ANSI/TIA 568-C.2 Patch	Nov. 2018	12
750	Polyrad® XT Transit Data Communications Cables	Nov. 2018	13
Section 3		Transit Specialty Cables	14-17
SPECIFICATION NUMBER	PRODUCT DESCRIPTION	REVISION DATE	PAGE NUMBER
5310	Diesel Locomotive Cable 2000 Volts (EPR/XL-CPE) UL RHH/RHW-2, 2000 V and c(UL) RW90, 1000 V Flexible, Oil-, Sunlight- and Ozone-Resistant, Flame-Retardant, -40°C to 90°C	Sept. 2016	15
755	Electronically Controlled Pneumatic (ECP) Brake Cable 600 V, Two Conductor, Unarmored and Armored	Feb. 2019	16
760	TRANSPower Head-End Power Cable (HEP) Single Conductor, 4/0 AWG 1000 V or Three Conductor, 10 AWG 600 V	Oct. 2017	17

Serving the Rail & Transit Markets

TABLE OF CONTENTS

Section 4		Technical Information	18-30	
SPECIFICATION NUMBER	PRODUCT DESCRIPTION	REVISION DATE	PAGE NUMBER	
General Technical Information				
A100	Common Color Sequence	Oct. 2017	19	
A125	Temperature Conversion Table	Oct. 2011	20	
A150	Metric Conversion Factors	Sept. 2010	21	
A186	AWG (American Wire Gauge) to mm ² (Millimeters Squared) Conversion	Oct. 2011	22	
Conductor Data				
B041	Class I Conductors for General Wiring	Oct. 2017	23	
B046	Class K Conductors for General Wiring	Oct. 2017	24	
Handling and Storage Recommendations				
D001	Minimum Bend Radius	Oct. 2017	25	
D005	Recommended Reel Handling Practices	May 2013	26	
D025	Recommended Cable Handling Practices	Oct. 2011	27	
D050	Recommended Cable Storage Practices	May 2013	28	
Catalog Number Index			29	

One Company Connecting The World™

POWERFUL PRESENCE · PRODUCTS PERFORMANCE · PEOPLE

General Cable has been a wire and cable innovator for over 170 years, always dedicated to connecting and powering people's lives. We are one of the largest wire and cable manufacturers in the world.

Our company serves customers through a network of manufacturing facilities in our core markets and has worldwide sales representation and distribution. We are dedicated to the production of high-quality aluminum, copper and fiber optic wire and cable and systems solutions for the energy, construction, industrial, specialty and communications sectors. With a vast portfolio of products to meet thousands of diverse application requirements, we continue to invest in research and development in order to maintain and extend our technology leadership by developing new materials, designing new products, and creating new solutions to meet tomorrow's market challenges.

In addition to our strong brand recognition and strengths in technology and manufacturing, General Cable is also competitive in such areas as distribution and logistics, marketing, sales and customer service. This combination enables us to better serve our customers globally and as they expand into new geographic markets.

General Cable offers our customers all the strengths and value of a large company, but our people give us the agility and responsiveness of a small one. We service you globally and locally.



Visit our Website at
www.generalcable.com



Corporate Social Responsibility

CREATING SHARED VALUE

General Cable believes corporate social responsibility (CSR) is about creating shared value. That means keeping a dual focus in our business decisions: what is good for us as a company and what contributes to the greater good of the communities in which we live and work.



SAFETY

Working safer by working together

General Cable has one worldwide safety vision and goal – **ZERO & BEYOND**. We measure safety performance globally, share best practices and implement sound health and safety management systems. Many of our facilities worldwide are OHSAS 18001 (safety management system) certified. All North American facilities have implemented an equivalent health and safety management system. General Cable was a pioneer in obtaining the OHSAS 18001 Certificate for Occupational Health and Safety Management Systems in Europe and North Africa.



SUSTAINABILITY

Responsible practices in daily operations

As a global leader in the wire and cable industry, General Cable recognizes its role and responsibility in promoting sustainability. Our strongest business value is continuous improvement in all areas of our company. Across our many businesses, the quest to introduce new and better products through continuous improvement in environmental designs reflects our commitment to achieving industry-leading standards and responding proactively to global environmental issues. General Cable was the first cable manufacturer to obtain certification for its environmental management system, in accordance with the ISO 14001 and EMAS Standards.



CITIZENSHIP

A commitment to being good citizens

Being responsible citizens in our communities is of the utmost importance to us. Unequivocal honesty, integrity, forthrightness and fair dealing have long been part of General Cable's core values and are expected globally in all of our business relationships with our customers, employees, suppliers, neighbors and competitors. Our company leaders and employees strive to make a difference throughout a host of volunteer activities and financial support, improving the communities in which we live and work.



INNOVATION

Technologies that power and connect the world

General Cable is delivering innovation that matters. We are focusing on R&D expertise and investing in developing wire and cable solutions that meet the challenges confronting our customers and the world. In working together and using all the ingenuity and creativity we have, we will reach the goal of being the preeminent supplier of wire and cabling solutions in the industry, with both green constructions and designs for the ever-growing renewable energy market.



A commitment to achieving industry-leading standards and responding proactively to environmental global issues.

+1.859.572.8000
info@generalcable.com

Visit www.GeneralCableCSR.com
to learn more.



Polyrad® XT Flexible Rail & Transit Wire and Cable

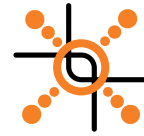

POLYRAD®

General Cable's Polyrad® XT rail & transit wire and cable is the chosen solution for demanding environments throughout North America and the world. Polyrad® XT is used extensively on all types of rapid transit and freight cars, heavy- and light-rail cars, diesel-electric locomotives and off-road vehicles.

Polyrad® XT rail & transit cables are specifically designed for original equipment and retrofit use in power and control circuits and in motor leads. Polyrad® XT's superior heat, flexibility and abrasion resistance, combined with its reduced size, simplifies cable installation and permits higher ampacities. Fully tested to meet all applicable specifications, Polyrad® XT cables ensure lifelong dependable service for transit, off-road and diesel-powered locomotives.

Unlike conventional insulating systems, Polyrad® XT offers a better balance of electrical properties for superior stability and performance. Available in both 600 volt and 2000 volt constructions, Polyrad® XT single-conductor rail & transit cables are dual-rated at 125°C and 110°C. Available in 600 volt and 2000 volt constructions, Polyrad® XT multi-conductor shielded and non-shielded rail & transit cables are rated at 125°C.



Polyrad® XT – The Trusted Name in Rail & Transit Wire and Cable

For more than 40 years, General Cable's Polyrad® XT has been the most respected name in rail & transit wire and cable. First introduced to the marine market for offshore oil rigs, ships and mobile land rigs, Polyrad® XT was developed to perform in the most rugged conditions, passing a wide range of stringent test procedures and standards. Since its introduction to the rail & transit markets, Polyrad® XT has been the leading wire and cable choice for rapid transit and freight cars, heavy- and light-rail cars, diesel-electric locomotives and off-road vehicles.



Polyrad® XT's Dual Rating

As the industry's first rail & transit wire and cable with a dual 125°C/110°C temperature rating, Polyrad® XT combines the superior properties and performance of a 125°C product while meeting all industry requirements for traditional 110°C transit wire. For distributors, this unique dual rating practically reduces inventory by half. Polyrad® XT meets all performance requirements of AAR RP-585 and ICEA S-95-658, as well as transit industry specifications.

Insulation System and Construction

Polyrad® XT insulation features a highly engineered and refined low-smoke polyolefin formulation used in conjunction with soft annealed tinned copper conductors per ASTM B33. This innovative insulation technology combines **outstanding flame retardance with excellent moisture-stable electrical values**. The construction is further enhanced by radiation cross-linking, which transforms the original thermoplastic into a rugged thermosetting material. The end result is a compound with **excellent thermal stability – it will not soften or flow at elevated temperatures**.

- Increased durability
- Greater resistance to cut-through
- Superior oil resistance
- Excellent low-temperature performance
- Maximum flexibility

Product Features and Benefits

Polyrad® XT wire and cables combine **superior electrical properties and performance** for advanced rapid transit, locomotive and off-road equipment applications.

- Dual 125°C/110°C temperature rating for long life, higher ampacities and protection from thermal overloads (single wires)
- Maximum flame retardance as demonstrated by VW-1 and, for multi-conductor cables, IEEE 383 (70,000 BTU/hr.) and IEEE 1202 (70,000 BTU/hr.)
- Excellent oil and chemical resistance
- Maximum dependability and mechanical toughness
- Smaller outside diameter and flexible stranding and insulation simplify installation



Phone: 866.248.7060
www.generalcable.com

Polyrad® XT Wire and Cable Testing

General Cable has perfected the technique of radiation processing. Cross-linking the insulation and jacket using our unique radiation process creates a more flexible product. In radiation cross-linking, a scanner accurately and uniformly directs a high-energy electron beam from a power source over the wire insulation, resulting in a precise degree of cross-linking. This technique enables General Cable to effectively process smaller wires with thin insulation walls to meet the transit market's critical demand for high-density cabling.

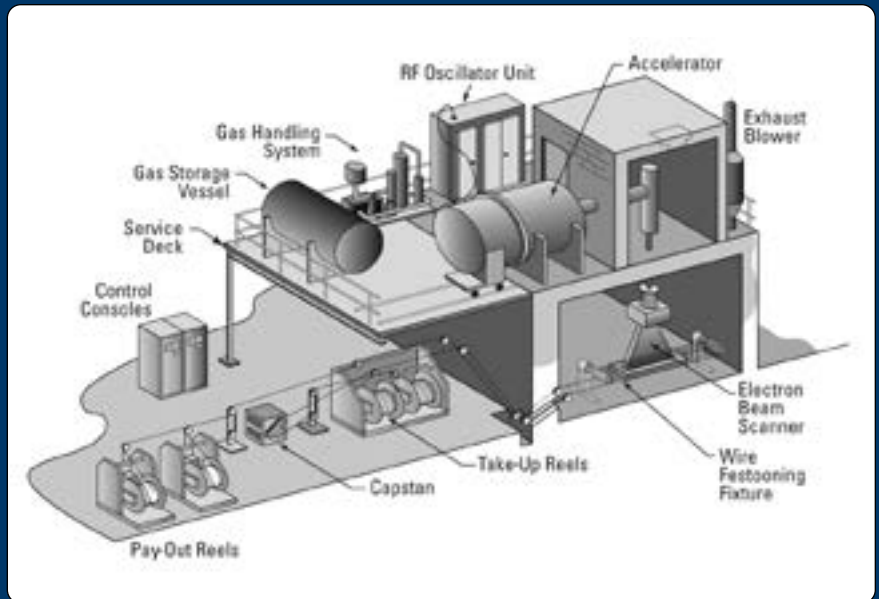

Electrical Properties

Requirement ICEA S-95-658		Typical General Cable*
Insulation Resistance @ 125°C (megohms-Mft)	2.0 Min.	8.3
Insulation Resistance Constant (K)	10,000 Min.	30,600
Long-Term Insulation Resistance 26 Weeks @ 90°C in water (megohms-Mft)	10 Min.	15
Accelerated Water Absorption Electrical SIC 24 hours @ 75°C	6.0 Max.	4.9
Increase in Capacitance, Percent		
1-14 Days	3.0 Max.	2.5
7-14 Days	1.5 Max.	1.3
Stability Factor after 14 days	1.0 Max.	0.18

Physical Properties

Requirement AAR RP-585 (S-501)		Typical General Cable*
Unaged Requirement		
Tensile Strength, Min. PSI	1,400 Min.	2,710
Elongation at Rupture, Min. %	200 Min.	260
Aged Requirement		
After Air Oven 7 days @ 158°C ± 2°C		
Tensile Strength (% of original)	90 Min.	100
Elongation (% of original)	50 Min.	69
Oil Immersion Aging – ASTM #2 18 hours @ 120°C		
Tensile Strength (% of original)	50 Min.	69
Elongation (% of original)	50 Min.	65
7 days @ 70°C		
Tensile Strength (% of original)	70 Min.	76
Elongation (% of original)	70 Min.	74
Hot Oil Resistance, % Swell 100 hours @ 150°C	60 Max.	32
Cold Bend @ -55°C	No Cracks	No Cracks
Cold Shock 1 hour @ -40°C	No Cracks	No Cracks
Cut-Through Penetration 10 minutes @ 125°C	No Failure	Pass

* Typical values are from various General Cable and independent laboratory testing.

Important Advantages of Radiation Cross-Linking

Advantage	Reason
More flexible cable	Pressure-applied insulation and jacket are not required
No separator tapes	Less pressure is applied during the radiation process
Free stripping	Insulation is not driven into the conductor stranding
Better electrical properties	No chemical catalyst required. No residues which lower electrical properties and corrode copper
Cables and interstices kept free of water	Water is not used in the radiation cure operation
Range of insulation thickness	Radiation process can economically cross-link thin or heavy walls
Permanent colors	Radiation does not change or fade colors. Tracer colors remain vivid

Standards

Polyrad® XT cables are manufactured, tested and inspected in accordance with the latest issue of the following standards:

AAR RP-585	Wiring and Cable Specification
ASTM B33	Tinned Soft or Annealed Copper Wire
ASTM D149	Test for Dielectric Breakdown Voltage and Dielectric Strength of Electrical Insulating Materials at Commercial Power Frequencies
ICEA S-95-658	Standard for Non-Shielded Power Cables Rated 2000 V or Less for the Distribution of Electrical Energy
UL 44	Standard for Rubber Insulated Wire and Cable
IEEE 1202	Standard for Flame Testing of cables for use in cable tray within Industrial and Commercial occupancies
NFPA® 130	Standard for Fixed Guideway Transit and Passenger Rail Systems



Phone: 866.248.7060
www.generalcable.com

Flame Test Comparison

The flammability of a cable is normally the ability of the material to cease burning once the source of heat is removed. Several tests have been formulated to measure this requirement.

UL FLAME TESTS

UL 1581 Vertical Tray Flame Test:

This test is conducted on cables lashed to a vertical metal ladder tray 8 feet in height. The combustion source is a ribbon burner with a flame temperature of approximately 1500°F which supplies 70,000 BTU of heat per hour. The flame application time is 20 minutes. This test requires the cable to self-extinguish prior to reaching the top of the tray which is 8 feet in height. A UL Type TC (Tray-Rated) cable must meet this test. UL 1581 is an equivalent test for IEEE 383-1974.

UL 1581 VW-1 Vertical Wire Flame Test:

This is a small-scale test conducted on a single 24" length of wire. The flame source is a Tirrill burner (similar to a Bunsen burner) with a heat output of approximately 3,000 BTU per hour. The flame is applied for 15 seconds and then is reapplied four more times. If the sample burns longer than 60 seconds after any application, or if the indicator flag or the cotton laid below the wire is ignited during the test, the cable fails the test.

Per AAR RP-585 – Application of the flame shall be 5 times with 15-second rest periods with 10 seconds maximum burn after each flame application.

Per NYCT - Application of the flame shall be 5 times with 15-second rest periods and 3 seconds maximum burn after each flame application.

NFPA 130 FLAME & SMOKE TEST

Per UL 1685 with FT4/IEEE 1202 Flame Exposure:

This test is conducted on cables attached to a vertical metal ladder tray 8 feet in height. The combustion source is a ribbon burner with a flame temperature of approximately 1500°F which supplies 70,000 BTUs/hr. The flame application time is 20 minutes. To pass this test, the resulting char distance must not be greater than 1.5 meters (59 inches) from the point of flame application, the total smoke released in 20 minutes shall not exceed 150 square meters, and peak smoke release rate shall not exceed 0.40 square meters per second.

TOXICITY TESTS

PER BSS 7239:

This test determines the toxic gas generated using the National Bureau of Standards (NBS) Smoke Density Chamber for sample combustion. Gases specifically measured are carbon monoxide (CO), hydrogen cyanide (HCN), sulfur dioxide (SO₂), hydrogen chloride (HCL), hydrogen fluoride (HF), nitrogen oxide (NO) and nitrogen dioxide (NO₂).

PER SMP-800C:

This test determines the toxic gas generated in a specified, calibrated chamber (typically ASTM E-662) during standard rate of smoke generation in both flaming and non-flaming test modes. Gases typically measured are carbon monoxide (CO), hydrogen cyanide (HCN), sulfur dioxide (SO₂), hydrogen chloride (HCL), hydrogen fluoride (HF), carbon dioxide (CO₂) and hydrogen bromide (HBr).

CSA FLAME TESTS

CSA FT4 Vertical Tray Flame Test (CSA C22.2 No. 03):

This test is conducted on cables lashed to a vertical metal ladder tray 8 feet in height. The combustion source is a ribbon burner with a flame temperature of approximately 1500°F which supplies 70,000 BTU of heat per hour. The flame application time is 20 minutes. To pass this test, the resulting char distance must not be greater than 1.5 meters (4.92 feet) from the point of flame application. This test is very similar to the IEEE 1202 flame test. It is also similar to but more severe than the UL 1581 Vertical Tray Flame Test.

[See UL 1581 Vertical Flame Test]

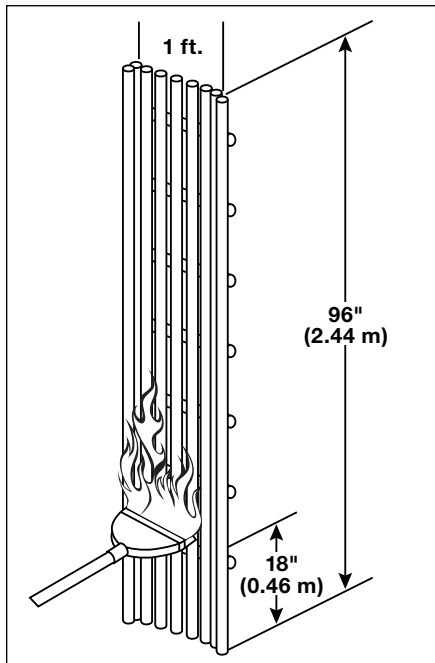

UL 1581 Vertical Tray Flame Test

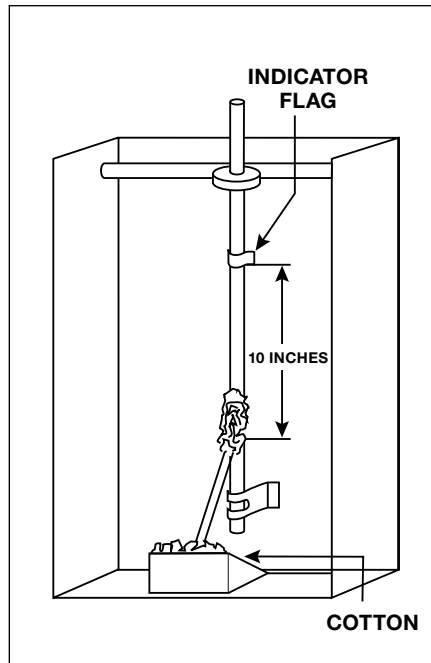

UL 1581 VW-1 Flame Test

Polyrad® XT, Polyrad® ULTRA and Polyrad® XT-TX 1 Wire and Cable Products

SPECIFICATION NUMBER	PRODUCT DESCRIPTION	REVISION DATE	PAGE NUMBER
700	Polyrad® XT Flexible Wire and Cable 600 V, Single Conductor, Dual Rated – 125°C/110°C	Nov. 2018	2
705	Polyrad® XT Flexible Wire and Cable 2000 V, Single Conductor, Dual Rated – 125°C/110°C	Nov. 2018	3
710	Polyrad® XT Multi-Conductor Cable 600 V, 125°C, Shielded	Nov. 2018	4
715	Polyrad® ULTRA Wire 600 V, Single Conductor, 125°C, Reduced Weight, Smaller Diameter, Dual Wall	Nov. 2018	5
720	Polyrad® ULTRA Multi-Conductor Cable 600 V, 125°C, Shielded	Nov. 2018	6
725	Polyrad® XT-TX Flexible Wire and Cable 600 V, Single Conductor, NYCT Type TX	Feb. 2019	7
730	Polyrad® XT-TX Flexible Wire and Cable 2000 V, Single Conductor, NYCT Type TX	Feb. 2019	8

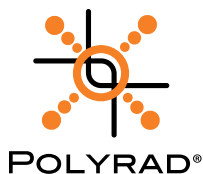

Polyrad® XT Flexible Wire and Cable

600 V, Single Conductor, Dual Rated – 125°C/110°C

Product Construction:

Conductor:

- 20 AWG thru 1111 kcmil soft annealed tinned copper per ASTM B33, B8 and B172

Insulation:

- Polyrad® XT flame-retardant, low-smoke irradiated Cross-linked Polyolefin (XLPO)

Print:

- GENERAL CABLE® (WC) POLYRAD® XT 125°C/110°C XXAWG 600 V DAY/MONTH/YEAR

Options:

- Available in multi-conductor constructions
- Class K stranding
- Available in colors other than dark gray

Applications:

- Ideally suited for use where environmental factors require cable characteristics to perform with a high degree of flame retardancy and excellent moisture-stable electrical values. Where reliability is the major concern and where maximum performance will be demanded
- Engineered and manufactured for both original equipment and retrofit use in power and control circuits and in motor leads
- Extensively found on all types of heavy- and light-rail cars, rapid transit cars, diesel-electric locomotives, freight cars and off-road vehicles

Features:

- Dual temperature rating at 125°C/110°C for long life, higher ampacities and protection from thermal overloads
- Excellent flexibility & free stripping
- Outstanding thermal stability at elevated temperatures
- Maximum flame retardance and low toxicity
- Excellent low-temperature performance; suitable for installation in sub-zero conditions
- Extra-tough, mechanically rugged irradiated thermoset insulation
- Resistant to most oils and chemicals
- Meets cold bend test at -55°C
- Meets cold impact test at -40°C

Compliances:

Industry:

- AAR S-501/AAR RP-585
- ICEA S-95-658

Flame Test:

- IEEE 1202/FT4 (70,000 BTU/hr)
- IEEE 383 (70,000 BTU/hr)
- VW-1

Other:

- BSS 7239
- SMP 800-C
- ASTM E662
- NFPA-130 (2017) On-Vehicle
- ASTM 1354
- RoHS and REACH Compliant

Packaging:

- Standard reel put-up

* For 14 AWG and larger

Color Code Chart

(Including but not limited to)

ORDERING SUFFIX	COLOR	ORDERING SUFFIX	COLOR
00	Dark Gray	05	Green
02	Red	08	Light Gray
04	Yellow	09	White



POLYRAD® XT 600 V

CATALOG NUMBER STOCK*	CONDUCTOR (AWG/kcmil) SIZE AND STRANDING		NOMINAL CONDUCTOR DIAMETER		NOMINAL INSULATION THICKNESS		NOMINAL CABLE DIAMETER		COPPER WEIGHT		NET CABLE WEIGHT		AMPACITY (FREE AIR 40°C AMBIENT)	
			INCHES	mm	MILS	mm	INCHES	mm	LBS/1000'	kg/km	LBS/1000'	kg/km	110°C	125°C
315130	20	19/32	0.038	0.97	30	0.76	0.098	2.49	4	6	8	12	15	17
280710*	18	19/30	0.048	1.21	30	0.76	0.108	2.74	6	9	11	16	17	19
280720*	16	19/29	0.054	1.37	30	0.76	0.114	2.90	8	12	13	19	23	25
280700*	14	19/27	0.067	1.70	30	0.76	0.127	3.23	12	18	17	25	39	42
296420*	12	19/25	0.086	2.18	30	0.76	0.146	3.71	19	28	26	39	51	55
303910*	10	27/24	0.117	2.97	30	0.76	0.177	4.50	34	50	42	63	67	72
296490	8	37/24	0.135	3.43	45	1.14	0.225	5.72	47	70	61	91	85	92
330230*	6	61/24	0.174	4.42	45	1.14	0.264	6.71	76	114	95	142	120	130
355320	5	91/24	0.242	6.15	45	1.14	0.332	8.43	116	173	139	211	151	163
318420	4	105/24	0.262	6.68	45	1.14	0.352	8.94	137	204	162	241	160	173
355330	3	125/24	0.285	7.24	45	1.14	0.375	9.53	167	284	191	284	199	215
355340	2	150/24	0.307	7.80	45	1.14	0.397	10.08	190	283	218	325	214	231
355350	1	225/24	0.380	9.65	55	1.40	0.490	12.45	287	427	346	515	247	267
355360	1/0	275/24	0.410	10.41	55	1.40	0.520	13.21	351	522	414	616	286	309
355370	2/0	325/24	0.470	11.94	55	1.40	0.580	14.73	407	606	471	701	329	355
355380	3/0	450/24	0.549	13.94	55	1.40	0.659	16.74	594	884	652	970	380	410
355390	4/0	550/24	0.593	15.06	55	1.40	0.703	17.86	696	1036	771	1147	446	482
355400	262	650/24	0.630	16.00	65	1.65	0.760	19.30	820	1220	913	1359	524	566
355410	313	775/24	0.685	17.40	65	1.65	0.815	20.70	987	1469	1089	1621	590	637
355420	373	925/24	0.750	19.05	65	1.65	0.880	22.35	1176	1750	1289	1918	657	710
355430	444	1100/24	0.820	20.83	65	1.65	0.950	24.13	1413	2207	1537	2287	734	793
355440	535	1325/24	0.895	22.73	80	2.03	1.055	26.80	1697	2525	1862	2771	828	894
355450	646	1600/24	0.980	24.89	80	2.03	1.140	28.96	2020	3006	2202	3277	931	1005
355460	777	1925/24	1.075	27.31	80	2.03	1.235	31.37	2435	3624	2564	3816	1047	1130
355470	929	2300/24	1.230	31.24	80	2.03	1.390	35.31	3117	4638	3401	5061	1168	1260
355480	1111	2750/24	1.328	33.73	95	2.41	1.518	38.56	3400	5060	3915	5826	1254	1354

Dimensions and weights are nominal; subject to industry tolerances.

Note: At the option of the purchaser, the manufacturer's standard type of stranding will be acceptable, providing that the conductor diameter does not exceed the values shown. The total number of wires shall be as specified, plus or minus one percent, except 150/24 which may vary by minus two percent, providing that the conductor diameter does not exceed the values shown.

*Standard stock items

Polyrad® XT Flexible Wire and Cable

2000 V, Single Conductor, Dual Rated – 125°C/110°C



POLYRAD® XT 2000 V – STANDARD INSULATION THICKNESS

CATALOG NUMBER STOCK*	CONDUCTOR (AWG/kcmil) SIZE AND STRANDING		NOMINAL CONDUCTOR DIAMETER		NOMINAL INSULATION THICKNESS		NOMINAL CABLE DIAMETER		COPPER WEIGHT		NET CABLE WEIGHT		AMPACITY (FREE AIR 40°C AMBIENT)	
			INCHES	mm	MILS	mm	INCHES	mm	LBS/1000'	kg/km	LBS/1000'	kg/km	110°C	125°C
364980	20	19/32	0.038	0.97	45	1.14	0.128	3.25	4	6	10	15	15	17
300620*	18	19/30	0.048	1.21	45	1.14	0.138	3.51	6	9	14	21	17	19
300890*	16	19/29	0.054	1.37	45	1.14	0.144	3.66	8	12	16	24	23	25
280740*	14	19/27	0.067	1.70	45	1.14	0.157	3.99	12	18	22	33	39	42
303480*	12	19/25	0.086	2.18	45	1.14	0.176	4.47	19	28	31	46	51	55
301260*	10	27/24	0.117	2.97	45	1.14	0.207	5.26	34	50	47	70	67	72
269970*	8	37/24	0.135	3.43	55	1.40	0.245	6.22	47	70	66	98	85	92
297970*	6	61/24	0.174	4.42	55	1.40	0.284	6.96	76	114	100	149	120	130
355490*	5	91/24	0.242	6.15	55	1.40	0.352	8.94	116	173	149	222	151	163
301270*	4	105/24	0.262	6.68	55	1.40	0.372	9.45	137	204	169	252	160	173
325290*	3	125/24	0.285	7.24	55	1.40	0.395	10.03	167	284	197	293	199	215
302440*	2	150/24	0.307	7.80	55	1.40	0.417	10.59	190	283	226	336	214	231
355500*	1	225/24	0.380	9.65	65	1.65	0.510	12.95	287	427	353	525	247	267
296500*	1/0	275/24	0.410	10.41	65	1.65	0.540	13.72	351	522	420	625	286	309
301280*	2/0	325/24	0.470	11.94	65	1.65	0.600	15.24	407	606	481	716	329	355
300900*	3/0	450/24	0.549	13.94	65	1.65	0.679	17.25	594	884	663	987	380	410
296510*	4/0	550/24	0.593	15.06	65	1.65	0.723	18.36	696	1036	792	1179	446	482
267040*	262	650/24	0.630	16.00	75	1.91	0.780	19.81	820	1220	931	1386	524	566
296520*	313	775/24	0.685	17.40	75	1.91	0.835	21.21	987	1469	1108	1649	590	637
304020*	373	925/24	0.750	19.05	75	1.91	0.900	22.86	1176	1750	1310	1950	657	710
300180	444	1100/24	0.820	20.83	75	1.91	0.970	24.64	1413	2207	1561	2323	734	793
263400*	535	1325/24	0.895	22.73	90	2.29	1.075	27.31	1697	2525	1888	2810	828	894
355570	646	1600/24	0.980	24.89	90	2.29	1.160	29.46	2020	3006	2231	3320	931	1005
260080	777	1925/24	1.075	27.31	90	2.29	1.255	31.88	2435	3624	2681	3990	1047	1130
355600	929	2300/24	1.230	31.24	90	2.29	1.410	35.81	3117	4638	3431	5106	1168	1260
355620	1111	2750/24	1.328	33.73	110	2.79	1.548	39.32	3400	5060	3972	5911	1254	1354

POLYRAD® XT 2000 V – HEAVY WALL INSULATION THICKNESS

355510	4/0	550/24	0.593	15.06	105	2.67	0.803	20.40	696	1036	837	1246	446	482
355520	262	650/24	0.630	16.00	105	2.67	0.840	21.34	820	1220	969	1442	524	566
355530	313	775/24	0.685	17.40	105	2.67	0.895	22.73	987	1469	1149	1710	590	637
355540	373	925/24	0.750	19.05	105	2.67	0.960	24.38	1176	1750	1353	2013	657	710
355550	444	1100/24	0.820	20.83	105	2.67	1.030	26.16	1413	2207	1607	2392	734	793
355560	535	1325/24	0.895	22.73	120	3.05	1.135	28.83	1697	2525	1946	2896	828	894
355580	646	1600/24	0.980	24.89	120	3.05	1.220	30.99	2020	3006	2285	3400	931	1005
355590	777	1925/24	1.075	27.31	120	3.05	1.315	33.40	2435	3624	2727	4058	1047	1130
355610	929	2300/24	1.230	31.24	120	3.05	1.470	37.34	3117	4638	3539	5267	1168	1260
355630	1111	2750/24	1.328	33.73	120	3.05	1.568	39.83	3400	5060	4011	5969	1254	1354

Dimensions and weights are nominal; subject to industry tolerances.

Note #1: Where additional insulation thickness is desired for added mechanical protection, these values are noted in the second chart.
 Note #2: At the option of the purchaser, the manufacturer's standard type of stranding will be acceptable providing that the conductor diameter does not exceed the values shown. The total number of wires shall be as specified, plus or minus one percent, except 150/24 which may vary by minus two percent, providing that the conductor diameter does not exceed the values shown.

*Standard stock items

Product Construction:

Conductor:

- 20 AWG thru 1111 kcmil soft annealed tinned copper per ASTM B33, B8 and B172

Insulation:

- Polyrad® XT flame-retardant, low-smoke irradiated Cross-linked Polyolefin (XLPO)

Print:

- GENERAL CABLE® (WC) POLYRAD® XT HW'
 125°C/110°C XXAWG 2000 V DAY/MONTH/YEAR
 * "HW" included for heavy-ware items

Options:

- Class K stranding
- Available in colors other than dark gray

Applications:

- Ideally suited for use where environmental factors require cable characteristics to perform with a high degree of flame retardancy and excellent moisture-stable electrical values. Where reliability is the major concern and where maximum performance will be demanded
- Engineered and manufactured for both original equipment and retrofit use in power and control circuits and in motor leads
- Extensively found on all types of heavy- and light-rail cars, rapid transit cars, diesel-electric locomotives, freight cars and off-road vehicles

Features:

- Dual temperature rating at 125°C/110°C for long life, higher ampacities and protection from thermal overloads
- Excellent flexibility and free stripping
- Outstanding thermal stability at elevated temperatures
- Maximum flame retardance and low toxicity
- Excellent low-temperature performance; suitable for installation in sub-zero conditions
- Extra-tough, mechanically rugged irradiated thermoset insulation
- Resistant to most oils and chemicals
- Meets cold bend test at -55°C
- Meets cold impact test at -40°C

Compliances:

Industry:

- AAR S-501/AAR RP-585
- ICEA S-95-658

Flame Test:

- IEEE 1202/FT4 (70,000 BTU/hr)
- IEEE 383 (70,000 BTU/hr)
- VW-1

Other:

- BSS 7239
- SMP 800-C
- ASTM E662
- NFPA-130 (2017) On-Vehicle
- ASTM 1354
- RoHS and REACH Compliant

Packaging:

- Standard reel put-up

* For 14 AWG and larger

Color Code Chart

(Including but not limited to)

ORDERING SUFFIX	COLOR	ORDERING SUFFIX	COLOR
00	Dark Gray	05	Green
02	Red	08	Light Gray
04	Yellow	09	White

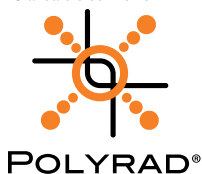

Polyrad® XT Multi-Conductor Cable

600 V, 125°C, Shielded

General Cable manufactures an extensive array of cables to support the many and diverse applications of transit infrastructures. To meet the needs of the evolving transit and locomotive industry, General Cable consistently brings new innovative cabling concepts to market with better technology, superior safety, easier and faster installation and extended performance. Polyrad® XT multi-conductor shielded rapid transit and locomotive car cables are rated at 125°C and 600 Volt.

Product Construction:

Conductor:

- 20 AWG thru 4/0 AWG soft annealed tinned copper per ASTM B33, B8 and B172

Insulation:

- Polyrad® XT flame-retardant, low-smoke irradiated Cross-linked Polyolefin (XLPO)
- Color Code: Method 1, E1

Shield:

- Tinned copper braid; 85% min. coverage

Jacket:

- Polyrad® XT flame-retardant, low-smoke irradiated Cross-linked Polyolefin (XLPO)

Print (Including but not limited to):

- GENERAL CABLE® (WC) POLYRAD® XT XX/COND XXAWG SHIELDED 125°C 600 V DAY/MONTH/YEAR

Options:

- Available in E2 or Method 4 color codes
- Foil shield with drain wire
- 2000 V

Applications:

- Ideally suited for use where environmental factors require cable characteristics to perform with a high degree of flame retardancy and excellent moisture-stable electrical values. Where reliability is the major concern and where maximum performance will be demanded



Applications (cont'd.):

- Engineered and manufactured for both original equipment and retrofit use in electronic equipment
- Extensively found on all types of heavy- and light-rail cars, rapid transit cars, diesel-electric locomotives, freight cars and off-road vehicles

Features:

- Temperature rating at 125°C for long life, higher ampacities and protection from thermal overloads
- Excellent flexibility and free stripping
- Outstanding thermal stability at elevated temperatures
- Maximum flame retardance
- Excellent low-temperature performance; suitable for installation in sub-zero conditions
- Extra-tough, mechanically rugged irradiated thermoset insulation and jacket
- Resistant to most oils and chemicals

Compliances:

Industry:

- ICEA S-95-658

Flame Test:

- IEEE 1202/FT4 (70,000 BTU/hr)
- IEEE 383 (70,000 BTU/hr)
- VW-1

Other:

- BSS 7239
- SMP 800-C
- ASTM E662
- NFPA-130 (2017) On-Vehicle
- RoHS and REACH Compliant

Packaging:

- Standard reel put-up

* For 14 AWG and larger

The multi-conductor cables shown in the following tables are merely a sampling of General Cable's wide range of products. Other conductor sizes, designs and/or specific installation requirements are available to meet virtually all the cabling needs of the transit and locomotive industry. For more information, contact General Cable's Transit inside sales at info@generalcable.com.

TWO CONDUCTOR POLYRAD® XT 600 V SHIELDED - 36 AWG TINNED COPPER BRAID - 85% MINIMUM COVERAGE

CATALOG NUMBER	AWG		INSULATED DIAMETER		JACKET THICKNESS		CABLE DIAMETER		NET CABLE WEIGHT	
	SIZE	STRANDING	INCHES	mm	MILS	mm	INCHES	mm	LBS/1000'	kg/km
324680	20	19/32	0.098	2.49	45	1.14	0.315	8.0	59	88
376760	18	19/30	0.108	2.74	45	1.14	0.330	8.4	63	94
373770	16	19/29	0.114	2.90	45	1.14	0.345	8.8	73	109
412170	14	19/27	0.127	3.23	45	1.14	0.370	9.4	86	130
373750	12	19/25	0.146	3.71	45	1.14	0.410	10.4	109	162

THREE CONDUCTOR POLYRAD® XT 600 V SHIELDED - 36 AWG TINNED COPPER BRAID - 85% MINIMUM COVERAGE

374360	20	19/32	0.098	2.49	45	1.14	0.325	8.3	68	88
387460	18	19/30	0.108	2.74	45	1.14	0.345	8.8	72	94
373780	16	19/29	0.114	2.90	45	1.14	0.360	9.2	87	130
412180	14	19/27	0.127	3.23	45	1.14	0.390	9.7	108	161
373760	12	19/25	0.146	3.71	45	1.14	0.430	10.9	139	162

FOUR CONDUCTOR POLYRAD® XT 600 V SHIELDED - 36 AWG TINNED COPPER BRAID - 85% MINIMUM COVERAGE

412190	20	19/32	0.098	2.49	45	1.14	0.355	9.0	81	121
387570	18	19/30	0.108	2.74	45	1.14	0.380	9.7	85	127
387070	16	19/29	0.114	2.90	45	1.14	0.390	9.9	106	158
412200	14	19/27	0.127	3.23	45	1.14	0.420	10.7	131	195
412210	12	19/25	0.146	3.71	45	1.14	0.465	11.8	176	262

Polyrad® ULTRA Wire

600 V, Single Conductor, 125°C, Reduced Weight, Smaller Diameter, Dual Wall

Through our wealth of experience in providing effective cabling solutions for challenging and hazardous environments, General Cable responds to yet another industry demand. As developments and opportunities in transit technology drive the adoption of more sophisticated train networks, available space decreases and becomes more costly. As a result, the transit industry is experiencing an increasing demand for the reduction of both size and weight of cabling systems. Polyrad® ULTRA wire offers better performance, reduced weight and smaller diameters, defining the next generation of cable, ideal where high-density cabling is required. Polyrad® ULTRA singles can be designed into multi-conductor constructions that are 600 Volt and rated 125°C, ideal for high-density cabling applications.

UP TO 33% WEIGHT & SPACE SAVINGS



Product Construction:

Conductor:

- 22 AWG thru 10 AWG soft annealed tinned copper per ASTM B33, B8 and B172

Dual Insulation:

- Polyrad® ULTRA flame-retardant, low-smoke irradiated Cross-linked Polyolefin (XLPO)
- Cross-linked fluoropolymer

Print:

- GENERAL CABLE® (WC) POLYRAD® ULTRA 125°C XXAWG 600 V DAY/MONTH/YEAR

Options:

- Available in multi-conductor constructions
- Available in colors other than dark gray

Applications:

- Ideally suited for use where high-density cabling is required, as this wire offers both size and weight advantages
- Engineered and manufactured for both original equipment and retrofit use in electronics equipment

Applications (cont'd):

- Utilized where environmental factors require wire characteristics to perform with a high degree of flame retardancy and excellent moisture-stable electrical values. Where reliability is the major concern and where maximum performance will be demanded
- For use on all types of heavy- and light-rail cars, rapid transit cars and diesel-electric locomotives

Features:

- Reduced diameter and lighter-weight transit wire — up to 33% smaller in diameter and lighter in weight than conventional Polyrad® XT 600 V
- Temperature rating at 125°C for long life, higher ampacities and protection from thermal overloads
- Outstanding thermal stability at elevated temperatures
- Maximum flame retardance
- Excellent low-temperature performance; suitable for installation in sub-zero conditions

Features (cont'd):

- Extra-tough, mechanically rugged irradiated thermoset insulation
- Resistant to most oils and chemicals
- Meets cold bend test at -55°C

Compliances:

- Flame Test:**
- IEEE 1202/FT4 (70,000 BTU/hr)
 - IEEE 383 (70,000 BTU/hr)
 - VW-1

Other:

- BSS 7239
- SMP 800-C
- ASTM E662
- NFPA-130 (2017) On-Vehicle
- ASTM 1354
- RoHS and REACH Compliant

Packaging:

- Standard reel put-up

* For 14 AWG and larger

POLYRAD® ULTRA 600 V

CATALOG NUMBER	CONDUCTOR (AWG) SIZE AND STRANDING		NOMINAL CONDUCTOR DIAMETER		NOMINAL INSULATION THICKNESS		NOMINAL JACKET THICKNESS		COPPER WEIGHT		NOMINAL CABLE DIAMETER		NET CABLE WEIGHT		AMPACITY (FREE AIR 40°C AMBIENT) 125°C
			INCHES	mm	MILS	mm	MILS	mm	LBS/1000'	kg/km	INCHES	mm	LBS/1000'	kg/km	
369550	22	19/34	0.030	0.76	10	0.254	5	0.127	2	3	0.060	1.53	4	6	14
369560	20	19/32	0.038	0.97	10	0.254	5	0.127	4	6	0.068	1.73	6	9	17
369570	18	19/30	0.048	1.22	10	0.254	5	0.127	6	9	0.078	1.98	8	12	19
369580	16	19/29	0.054	1.37	10	0.254	5	0.127	8	12	0.084	2.13	10	15	25
369590	14	19/27	0.067	1.70	10	0.254	5	0.127	12	18	0.097	2.46	15	22	42
369600	12	19/25	0.086	2.18	10	0.254	5	0.127	19	28	0.116	2.95	23	34	55
369610	10	65/28	0.111	2.82	10	0.254	5	0.127	33	49	0.141	3.58	37	55	72

Dimensions and weights are nominal; subject to industry tolerances.

Color Code Chart

(Including but not limited to)

ORDERING SUFFIX	COLOR	ORDERING SUFFIX	COLOR
00	Dark Gray	05	Green
02	Red	08	Light Gray
04	Yellow	09	White

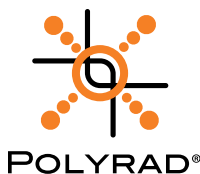

Polyrad® ULTRA Multi-Conductor Cable

600 V, 125°C, Shielded

Through a wealth of experience providing effective cabling solutions for challenging and hazardous environments, General Cable responds to yet another industry demand by defining the next generation of cable — Polyrad® ULTRA. As developments and opportunities in transit technology drive the adoption of more sophisticated transit infrastructures, available space decreases. Consequently, the transit industry is experiencing an increasing demand for reduced size and weight of cabling systems. Ideal wherever space is at a premium and high-density cabling is required, Polyrad® ULTRA cables offer better performance, reduced weight and smaller diameters. Polyrad® ULTRA singles are designed into multi-conductor 600 Volt constructions rated at 125°C to meet a variety of high-density cabling applications.

Product Construction:

Conductor:

- 22 AWG thru 10 AWG soft annealed tinned copper per ASTM B33, B8 and B172

Insulation:

- Polyrad® ULTRA flame-retardant, low-smoke irradiated Cross-linked Polyolefin (XLPO)
- Cross-linked fluoropolymer
- Color code: Method 1, E1

Shield Options:

- Tinned copper braid
- Foil with drain wire
- Non-shielded

Jacket:

- Polyrad® XT flame-retardant, low-smoke irradiated Cross-linked Polyolefin (XLPO)

Print (Including but not limited to):

- GENERAL CABLE® (WC) POLYRAD® ULTRA XX/COND XXAWG SHIELDED 125°C 600 V YEAR/MONTH

Options:

- Available in E2 or Method 4 color codes
- Available in non-shielded

Applications:

- Ideally suited for use where high-density cabling is required, as these cables offer both size and weight advantages
- Engineered and manufactured for both original equipment and retrofit use in electronic equipment
- Utilized where environmental factors require cable characteristics to perform with a high degree of flame retardancy and excellent moisture-stable electrical values. Where reliability is the major concern and where maximum performance will be demanded
- For use on all types of heavy- and light-rail cars, rapid transit cars and diesel-electric locomotives

Features:

- Reduced diameter and lighter-weight transit cable - 25% smaller in diameter and lighter in weight than conventional Polyrad® XT 600 V
- Temperature rating at 125°C for long life, higher ampacities and protection from terminal overloads

The multi-conductor cables shown in the following tables are merely a sampling of General Cable's wide range of products.

Other conductor sizes, designs and/or specific installation requirements are available to meet virtually all the cabling needs of the transit and locomotive industry. For more information, contact General Cable's Transit inside sales at info@generalcable.com.



Features (cont'd.):

- Higher ampacities and simplified installations possible due to small outside diameters, flexible stranding and insulation
- Outstanding thermal stability at elevated temperatures
- Maximum flame retardance
- Excellent low-temperature performance; suitable for installation in sub-zero conditions
- Extra-tough, mechanically rugged irradiated thermoset insulation and jacket
- Resistant to most oils and chemicals

Compliances:

Flame Test:

- IEEE 1202/FT4 (70,000 BTU/hr)
- IEEE 383 (70,000 BTU/hr)
- VW-1

Other:

- BSS 7239
- SMP 800-C
- ASTM E662
- NFPA-130 (2017) On-Vehicle
- RoHS and REACH Compliant

Packaging:

- Standard reel put-up

* For 14 AWG and larger

CATALOG NUMBER	AWG		INSULATED DIAMETER		JACKET THICKNESS		CABLE DIAMETER		NET CABLE WEIGHT	
	SIZE	STRANDING	INCHES	mm	MILS	mm	INCHES	mm	LBS/1000'	kg/km
TWO CONDUCTOR POLYRAD® ULTRA SHIELDED - 36 AWG TINNED COPPER BRAID - 85% MINIMUM COVERAGE										
398600	22	19/34	0.060	1.53	20	0.51	0.185	4.7	23	34
398610	20	19/32	0.068	1.73	20	0.51	0.200	5.1	30	45
398620	18	19/30	0.078	1.98	20	0.51	0.220	5.6	36	54
387710	16	19/29	0.084	2.13	20	0.51	0.235	6.0	42	61
398630	14	19/27	0.097	2.46	20	0.51	0.260	6.6	54	80
398640	12	19/25	0.116	2.95	20	0.51	0.300	7.6	73	109
398650	10	65/28	0.147	3.81	20	0.51	0.365	9.3	112	167
THREE CONDUCTOR POLYRAD® ULTRA SHIELDED - 36 AWG TINNED COPPER BRAID - 85% MINIMUM COVERAGE										
398730	22	19/34	0.060	1.53	20	0.51	0.195	5.0	29	43
398740	20	19/32	0.068	1.73	20	0.51	0.210	5.3	37	55
387730	18	19/30	0.078	1.98	20	0.51	0.235	6.0	45	67
398750	16	19/29	0.084	2.13	20	0.51	0.245	6.2	52	77
398760	14	19/27	0.097	2.46	20	0.51	0.275	7.0	69	103
398770	12	19/25	0.116	2.95	20	0.51	0.315	8.0	96	143
398780	10	65/28	0.147	3.81	20	0.51	0.385	9.8	149	222
FOUR CONDUCTOR POLYRAD® ULTRA SHIELDED - 36 AWG TINNED COPPER BRAID - 85% MINIMUM COVERAGE										
443360	22	19/34	0.060	1.53	20	0.51	0.215	5.5	34	51
443370	20	19/32	0.068	1.73	20	0.51	0.235	6.0	42	63
418530	18	19/30	0.078	1.98	20	0.51	0.250	6.3	54	80
418460	16	19/29	0.084	2.13	20	0.51	0.270	6.9	66	98
418510	14	19/27	0.097	2.48	20	0.51	0.300	7.6	89	132
443380	12	19/25	0.116	2.95	20	0.51	0.345	8.8	124	185
443390	10	65/28	0.147	3.81	20	0.51	0.410	10.4	192	286

Polyrad® XT-TX Flexible Wire and Cable

600 V, Single Conductor, NYCT Type TX



POLYRAD® XT-TX 600 V

CATALOG NUMBER	NYCT TYPE TX STOCK CODE NUMBER	CONDUCTOR (AWG/kcmil) SIZE AND STRANDING		NOMINAL CONDUCTOR DIAMETER				NOMINAL CABLE DIAMETER		COPPER WEIGHT		NET CABLE WEIGHT		AMPACITY (FREE AIR 40°C AMBIENT)
				INCHES	mm	MILS	mm	INCHES	mm	LBS/ 1000'	kg/ km	LBS/ 1000'	kg/ km	
389980	*	20	19/32	0.038	0.97	30	0.76	0.100	2.54	4	6	9	13	15
389990	20-88-150X	18	19/30	0.048	1.22	30	0.76	0.110	2.79	6	9	12	18	17
389740	20-88-170X	16	19/29	0.054	1.37	30	0.76	0.116	2.95	8	13	13	19	23
390000	20-88-190X	14	19/27	0.067	1.70	30	0.76	0.129	3.28	12	18	18	27	39
390010	20-88-210X	12	19/25	0.086	2.18	30	0.76	0.148	3.76	19	28	27	40	51
390020	20-88-230X	10	27/24	0.117	2.97	30	0.76	0.179	4.55	34	50	43	64	67
390030	20-88-250X	8	37/24	0.135	3.43	45	1.14	1.227	5.77	47	70	63	94	85
390040	20-88-270X	6	61/24	0.174	4.42	45	1.14	0.266	6.75	76	114	97	144	120
390050	*	5	91/24	0.242	6.15	45	1.14	0.334	8.48	116	173	141	210	151
390060	20-88-290X	4	105/24	0.262	6.65	45	1.14	0.354	8.99	137	204	164	244	160
390070	20-88-310X	3	125/24	0.285	7.24	45	1.14	0.377	9.58	167	249	193	287	199
390080	20-88-330X	2	150/24	0.307	7.80	45	1.14	0.399	10.14	190	283	220	327	214
390090	20-88-380X	1	225/24	0.380	9.65	55	1.40	0.494	12.55	287	427	349	519	247
390100	*	1/0	275/24	0.410	10.41	55	1.40	0.524	13.31	351	522	417	621	286
390110	*	2/0	325/24	0.470	11.94	55	1.40	0.584	14.83	407	606	474	705	329
390120	*	3/0	450/24	0.549	13.94	55	1.40	0.663	16.84	594	884	655	975	380
390130	20-88-460X	4/0	550/24	0.593	15.06	55	1.40	0.707	17.96	696	1036	774	1152	446

Dimensions and weights are nominal; subject to industry tolerances.

Note: At the option of the purchaser, the manufacturer's standard type of stranding will be acceptable, providing that the conductor diameter does not exceed the values shown. The total number of wires shall be as specified, plus or minus one percent, except 150/24 which may vary by minus two percent, providing that the conductor diameter does not exceed the values shown.

*Sizes without NYCT Type TX stock code numbers are not listed in the NYCT TX specification.

Color Code Chart
(Including but not limited to)

ORDERING SUFFIX	COLOR	ORDERING SUFFIX	COLOR
00	Dark Gray	05	Green
02	Red	08	Light Gray
04	Yellow	09	White

Product Construction:

Conductor:

- 20 AWG thru 4/0 AWG soft annealed tinned copper per ASTM B33, B8 and B172

Insulation:

- Polyrad® XT flame-retardant, low-smoke irradiated Cross-linked Polyolefin (XLPO)

Print:

- GENERAL CABLE® (WC) POLYRAD® XT-TX 1/C XXAWG 600 V NYCT TX 20-88-XXXX DAY/MONTH/YEAR
XXXX = NYCT TX Stock Code - last x is used to identify insulation color as listed below:
0 = Black, 1 = White, 2 = Red, 3 = Blue, 4 = Green, 5 = Orange, 6 = Yellow, 7 = Gray, 8 = Brown, 9 = Purple

Options:

- Available in multi-conductor constructions
- Available in colors other than dark gray

Applications:

- Ideally suited for use where environmental factors require cable characteristics to perform with a high degree of flame retardancy and excellent moisture-stable electrical values. Where reliability is the major concern and where maximum performance will be demanded
- Engineered and manufactured for both original equipment and retrofit use in power and control circuits and in motor leads
- Extensively found on all types of heavy- and light-rail cars, rapid transit cars, diesel-electric locomotives, freight cars and off-road vehicles

Features:

- Cables meet NYCT TX specification
- Temperature rating at 110°C
- Excellent flexibility & free stripping
- Outstanding thermal stability at elevated temperatures
- Maximum flame retardance and low toxicity
- Excellent low-temperature performance; suitable for installation in sub-zero conditions
- Extra-tough, mechanically rugged irradiated thermoset insulation
- Resistant to most oils and chemicals
- Meets cold bend test at -55°C
- Meets cold impact test at -40°C

Compliances:

Industry:

- AAR S-501/AAR RP-585
- ICEA S-95-658

Flame Test:

- IEEE 1202/FT4 (70,000 BTU/hr)
- IEEE 383 (70,000 BTU/hr)
- VW-1

Other:

- Meets NYCT TX specification
- BSS 7239
- SMP 800-C
- ASTM E662
- NFPA-130 (2017) On-Vehicle

Packaging:

- Standard reel put-up

* For 14 AWG and larger

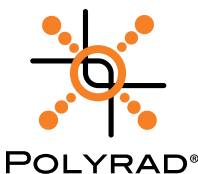

Polyrad® XT-TX Flexible Wire and Cable

2000 V, Single Conductor, NYCT Type TX

Product Construction:

Conductor:

- 20 AWG thru 535 kcmil soft annealed tinned copper per ASTM B33, B8 and B172

Insulation:

- Polyrad® XT flame-retardant, low-smoke irradiated Cross-linked Polyolefin (XLPO)

Print:

- GENERAL CABLE® (WC) POLYRAD® XT-TX 1/C XXAWG 2000 V NYCT TX 20-90-XXXX DAY/MONTH/YEAR XXXX = NYCT TX Stock Code - last x is used to identify insulation color as listed below:
0 = Black, 1 = White, 2 = Red, 3 = Blue, 4 = Green, 5 = Orange, 6 = Yellow, 7 = Gray, 8 = Brown, 9 = Purple

Options:

- Available in colors other than dark gray

Applications:

- Ideally suited for use where environmental factors require cable characteristics to perform with a high degree of flame retardancy and excellent moisture-stable electrical values. Where reliability is the major concern and where maximum performance will be demanded
- Engineered and manufactured for both original equipment and retrofit use in power and control circuits and in motor leads
- Extensively found on all types of heavy- and light-rail cars, rapid transit cars, diesel-electric locomotives, freight cars and off-road vehicles

Features:

- Cables meet NYCT TX specification
- Temperature rating at 110°C
- Excellent flexibility and free stripping
- Outstanding thermal stability at elevated temperatures
- Maximum flame retardance and low toxicity
- Excellent low-temperature performance; suitable for installation in sub-zero conditions
- Extra-tough, mechanically rugged irradiated thermoset insulation
- Resistant to most oils and chemicals
- Meets cold bend test at -55°C
- Meets cold impact test at -40°C

Compliances:

Industry:

- AAR S-501/AAR RP-585
- ICEA S-95-658

Flame Test:

- IEEE 1202/FT4 (70,000 BTU/hr)
- IEEE 383 (70,000 BTU/hr)
- VW-1

Other:

- Meets NYCT TX specification
- BSS 7239
- SMP 800-C
- ASTM E662
- NFPA-130 (2017) On-Vehicle

Packaging:

- Standard reel put-up

* For 14 AWG and larger



POLYRAD® XT-TX 2000 V

CATALOG NUMBER	NYCT TYPE TX STOCK CODE NUMBER	CONDUCTOR (AWG/kcmil) SIZE AND STRANDING		NOMINAL CONDUCTOR DIAMETER		MINIMUM AVERAGE INSULATION THICKNESS		NOMINAL CABLE DIAMETER		COPPER WEIGHT		NET CABLE WEIGHT		AMPACITY (FREE AIR 40°C AMBIENT)
				INCHES	mm	MILS	mm	INCHES	mm	LBS/ 1000'	kg/ km	LBS/ 1000'	kg/ km	110°C
390500	*	20	19/32	0.038	0.97	45	1.14	0.130	3.30	4	6	11	16	15
390140	20-90-160X	18	19/30	0.048	1.22	45	1.14	0.140	3.56	6	9	15	22	17
390150	20-90-180X	16	19/29	0.054	1.37	45	1.14	0.146	3.71	8	13	17	25	23
390160	20-90-200X	14	19/27	0.067	1.70	45	1.14	0.159	4.04	12	18	23	34	39
390170	20-90-220X	12	19/25	0.086	2.18	45	1.14	0.178	4.52	19	28	32	48	51
390180	20-90-240X	10	27/24	0.117	2.97	45	1.14	0.209	5.31	34	50	49	73	67
390190	20-90-260X	8	37/24	0.135	3.43	55	1.40	0.249	6.33	47	70	68	101	85
390200	20-90-280X	6	61/24	0.174	4.60	55	1.40	0.288	7.32	76	114	104	155	120
390210	*	5	91/24	0.242	6.15	55	1.40	0.356	9.04	116	173	149	222	151
390220	20-90-320X	4	105/24	0.262	6.65	55	1.40	0.376	9.55	137	204	172	256	160
390230	20-90-340X	3	125/24	0.285	7.24	55	1.40	0.399	10.14	167	249	201	299	199
390240	20-90-360X	2	150/24	0.307	7.80	55	1.40	0.421	10.69	190	283	230	343	214
390250	20-90-380X	1	225/24	0.380	9.65	65	1.65	0.514	13.06	287	427	357	531	247
390260	20-90-400X	1/0	275/24	0.410	10.41	65	1.65	0.544	13.82	351	522	424	631	286
389730	20-90-420X	2/0	325/24	0.470	11.94	65	1.65	0.604	15.34	407	606	485	722	329
390270	20-90-440X	3/0	450/24	0.549	13.94	65	1.65	0.683	17.35	594	884	667	993	380
390280	20-90-460X	4/0	550/24	0.593	15.06	65	1.65	0.727	18.47	696	1036	796	1185	446
390290	20-90-480X	262	650/24	0.630	16.00	105	2.67	0.844	21.44	820	1220	936	1393	524
389750	20-90-500X	313	775/24	0.685	17.40	105	2.67	0.899	26.30	987	1469	1113	1656	590
390300	20-90-520X	373	925/24	0.750	19.05	105	2.67	0.964	24.49	1176	1750	1315	1957	657
390310	20-90-540X	444	1100/24	0.820	20.83	105	2.67	1.034	26.26	1413	2103	1566	2330	734
390320	20-90-560X	535	1325/24	0.895	22.73	105	2.67	1.109	28.17	1697	2525	1894	2819	828

Dimensions and weights are nominal; subject to industry tolerances.

Note: At the option of the purchaser, the manufacturer's standard type of stranding will be acceptable, providing that the conductor diameter does not exceed the values shown. The total number of wires shall be as specified, plus or minus one percent, except 150/24 which may vary by minus two percent, providing that the conductor diameter does not exceed the values shown.

*Sizes without NYCT Type TX stock code numbers are not listed in the NYCT TX specification.

Color Code Chart
(Including but not limited to)

ORDERING SUFFIX	COLOR	ORDERING SUFFIX	COLOR
00	Dark Gray	05	Green
02	Red	08	Light Gray
04	Yellow	09	White

Transit Data Communications Cables 2

SPECIFICATION NUMBER	PRODUCT DESCRIPTION	REVISION DATE	PAGE NUMBER
735	Category 5e Low-Smoke, Zero-Halogen Shielded Cable 4 Pair, 24 AWG, ANSI/TIA 568-C.2 Patch	Nov. 2018	10
740	Category 5e Quad Low-Smoke, Zero-Halogen Shielded Cable 2 Pair, 22 AWG, ANSI/TIA 568-C.2 Patch	Nov. 2018	11
745	Category 6 Low-Smoke, Zero-Halogen Shielded Cable 4 Pair, 24 AWG, ANSI/TIA 568-C.2 Patch	Nov. 2018	12
750	Polyrad® XT Transit Data Communications Cables	Nov. 2018	13

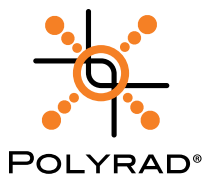

Category 5e Low-Smoke, Zero-Halogen Shielded Cable

4 Pair, 24 AWG, ANSI/TIA 568-C.2 Patch

Product Construction:

Conductor:

- 4 pair, 24 AWG 7/32 tinned copper

Insulation:

- Polyolefin

Pairs:

- Two conductors twisted together (each pair twisted with a different lay length)
- Color code:
 - P1: White/Blue, Blue
 - P2: White/Orange, Orange
 - P3: White/Green, Green
 - P4: White/Brown, Brown

Binding:

- Low-Smoke, Zero-Halogen (LSZH) flame-retardant tape

Inner Shield:

- Aluminum/polyester tape, 100% coverage

Outer Shield:

- Tinned copper braid, 60% coverage

Jacket:

- Low-Smoke, Zero-Halogen irradiated Cross-linked Polyolefin (LSZH XLPO), Gray

Print (Including but not limited to):

- GENERAL CABLE® – 443230--4PR/24 AWG SF/UTP CAT 5E PATCH 75°C LSZH (UL) CMG-LS E105765-W – ROHS AND NFPA 130 COMPLIANT YYMMDD XXXXT

Applications:

- Category 5e SF/UTP construction is suitable for use in on-vehicle transit applications with flexible stranding, overall shield and Low-Smoke, Zero-Halogen (LSZH) cross-linked jacket

Features:

- Meets Category 5e electricals (tested to 200 MHz)
- Overall metal braid and AL/Mylar tape provide protection from EMI noise
- Low-Smoke, Zero-Halogen (LSZH) jacket is environmentally friendly
- Low-Smoke, Zero-Halogen (LSZH) jacket reduces the amount of toxic and corrosive gases emitted during combustion, providing a safer environment for personnel and equipment during the hazards of fire

Compliances:

Industry:

- (UL) CMG-LS Listed E105765
- (UL) verified ANSI/TIA 568-C.2 Patch
- ISO/IEC 11801 Ed. 2.2
- Oil-Resistant per EN 50306-4

Flame Test:

- UL 1685 FT4 W/IEEE 1202 Limited Smoke
- IEC 60332-3-24
- ASTM E662 Smoke Emission
- BSS 7239 Combustion Toxicity
- IEC 61156-1

Other:

- NFPA-130 (2017) On-Vehicle
- RoHS and REACH Compliant



TRANSIT, 4 PAIR/24 AWG, SHIELDED FOIL TWISTED PAIR (SF/UTP) CAT 5e, LOW-SMOKE, ZERO-HALOGEN

CATALOG NUMBER	# OF PAIRS	CONDUCTOR SIZE		NOM. COND. DIAMETER		NOM. INS. O.D.		NOM. JACKET THICKNESS		NOM. CABLE DIAMETER		NET CABLE WEIGHT	
		AWG	STRAND.	INCHES	mm	INCHES	mm	INCHES	mm	INCHES	mm	LBS/1000'	kg/km
443230	4	24	7/32	0.024	0.61	0.043	1.1	0.025	0.64	0.275	7.0	43.1	64.1

ELECTRICAL CHARACTERISTICS

FREQUENCY (MHz)	INSERTION LOSS (dB/100 m)	NEXT (dB)	ACRF (dB)	RL (dB)
	max.	min.	min.	min.
1	2.4	65.3	63.8	20.0
4	4.9	56.3	51.8	23.0
10	7.8	50.3	43.8	25.0
16	9.9	47.2	39.7	25.0
20	11.1	45.8	37.8	25.0
25	12.5	44.3	35.8	24.2
31.25	14.1	42.9	33.9	23.3
62.5	20.4	38.4	27.9	20.7
100	26.4	35.3	23.8	19.0
150	33.1	32.7	20.3	17.5
200	38.9	30.8	17.8	16.4

- DC Resistance:** 9.5 Ω /100 m Max.
- DCR Unbalanced:** 4% Max.
- Mutual Capacitance:** 5.6 nF/100 m Max.
- Capacitance Unbalanced:** 160 pF/100 m Max.
- Characteristic Impedance:** 100 Ω +/- 15 Ω
- Prop Delay (Skew):** 45 ns/100 m Max.
- Velocity of Propagation:** 72% Nom.
- Temperature:** Operation: -40°C to +75°C
Installation: 0°C to +60°C
- Bend Radius:** 4.2" Min.

Category 5e Quad Low-Smoke, Zero-Halogen Shielded Cable

2 Pair, 22 AWG, ANSI/TIA 568-C.2 Patch



TRANSIT, 2 PAIR/22 AWG, SHIELDED FOIL TWISTED PAIR (SF/UTP) CAT 5e, LOW-SMOKE, ZERO-HALOGEN

CATALOG NUMBER	# OF PAIRS	CONDUCTOR SIZE		NOM. COND. DIAMETER		NOM. INS. O.D.		NOM. JACKET THICKNESS		NOM. CABLE DIAMETER		NET CABLE WEIGHT	
		AWG	STRAND.	INCHES	mm	INCHES	mm	INCHES	mm	INCHES	mm	LBS/1000'	kg/km
443240	2	22	7/30	0.030	0.76	0.053	1.35	0.025	0.64	0.275	7.0	42.3	62.9

ELECTRICAL CHARACTERISTICS

FREQUENCY (MHz)	INSERTION LOSS (dB/100 m)	NEXT (dB)	ACRF (dB)	RL (dB)
	max.	min.	min.	min.
1	2.4	65.3	63.8	20.0
4	4.9	56.3	51.8	23.0
10	7.8	50.3	43.8	25.0
16	9.9	47.2	39.7	25.0
20	11.1	45.8	37.8	25.0
25	12.5	44.3	35.8	24.2
31.25	14.1	42.9	33.9	23.3
62.5	20.4	38.4	27.9	20.7
100	26.4	35.3	23.8	19.0
155	33.1	32.7	20.3	17.5
200	38.9	30.8	17.8	16.4

DC Resistance: 9.5 Ω /100 m Max.
DCR Unbalanced: 4% Max.
Mutual Capacitance: 5.6 nF/100 m Max.
Capacitance Unbalanced: 160 pF/100 m Max.
Characteristic Impedance: 100 Ω +/- 15 Ω
Prop Delay (Skew): 45 ns/100 m Max.
Velocity of Propagation: 72% Nom.
Temperature: Operation: -40°C to +75°C
 Installation: 0°C to +60°C
Bend Radius: 4.2" Min.

Product Construction:

- Conductor:**
 - 2 pair, 22 AWG 7/30 tinned copper
- Insulation:**
 - Polyolefin
- Pairs:**
 - Two conductors twisted together (each pair twisted with a different lay length)
 - Color code:
 - P1: Orange, Blue
 - P2: White, Yellow

Binding:

- Low-Smoke, Zero-Halogen (LSZH) flame-retardant tape

Inner Shield:

- Aluminum/polyester tape, 100% coverage

Outer Shield:

- Tinned copper braid, 60% coverage

Jacket:

- Low-Smoke, Zero-Halogen irradiated Cross-linked Polyolefin (LSZH XLPO), Gray

Print (Including but not limited to):

- GENERAL CABLE® – 443240--2PR/22 AWG SF/UTP CAT 5E PATCH 75°C LSZH (UL) CMG-LS E105765-W – ROHS AND NFPA 130 COMPLIANT YYMMDD XXXXFT

Applications:

- Category 5e Quad SF/UTP construction is suitable for use in on-vehicle transit applications with flexible stranding, overall shield and Low-Smoke, Zero-Halogen (LSZH) cross-linked jacket

Features:

- Meets Category 5e electricals (tested to 100 MHz)
- Overall metal braid and AL/Mylar tape provide protection from EMI noise
- Low-Smoke, Zero-Halogen (LSZH) jacket is environmentally friendly
- Low-Smoke, Zero-Halogen (LSZH) jacket reduces the amount of toxic and corrosive gases emitted during combustion, providing a safer environment for personnel and equipment during the hazards of fire

Compliances:

Industry:

- (UL) CMG-LS Listed E105765
- (UL) verified ANSI/TIA 568-C.2 Patch
- ISO/IEC 11801 Ed. 2.2
- Oil-Resistant per EN 50306-4

Flame Test:

- UL 1685 FT4 W/IEEE 1202 Limited Smoke
- IEC 60332-3-24
- ASTM E662 Smoke Emission
- BSS 7239 Combustion Toxicity
- IEC 61156-1

Other:

- NFPA-130 (2017) On-Vehicle
- RoHS and REACH Compliant

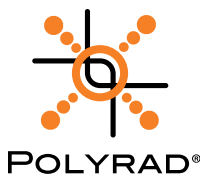

Category 6 Low-Smoke, Zero-Halogen Shielded Cable

4 Pair, 24 AWG, ANSI/TIA 568-C.2 Patch

Product Construction:

Conductor:

- 4 pair, 24 AWG 7/32 tinned copper

Insulation:

- Polyolefin

Pairs:

- Two conductors twisted together (each pair twisted with a different lay length)
- Color code:
 - P1: White/Blue, Blue
 - P2: White/Orange, Orange
 - P3: White/Green, Green
 - P4: White/Brown, Brown

Separator:

- Low-Smoke, Zero-Halogen (LSZH) flame-retardant cross-web

Binding:

- Low-Smoke, Zero-Halogen (LSZH) flame-retardant tape

Inner Shield:

- Aluminum/polyester tape, 100% coverage

Outer Shield:

- Tinned copper braid, 60% coverage

Jacket:

- Low-Smoke, Zero-Halogen irradiated Cross-linked Polyolefin (LSZH XLPO), Gray

Print (Including but not limited to):

- GENERAL CABLE® –443480–4PR/24 AWG SF/UTP CAT 6 PATCH 75°C LSZH (UL) CMG-LS E105765-W – ROHS AND NFPA 130 COMPLIANT YMMDD XXXXT

Applications:

- Category 6 SF/UTP construction is suitable for use in on-vehicle transit applications with flexible stranding, overall shield and Low-Smoke, Zero-Halogen (LSZH) cross-linked jacket

Features:

- Meets Category 6 electricals (tested to 350 MHz)
- Overall metal braid and AL/Mylar tape provide protection from EMI noise
- Low-Smoke, Zero-Halogen (LSZH) jacket is environmentally friendly
- Low-Smoke, Zero-Halogen (LSZH) jacket reduces the amount of toxic and corrosive gases emitted during combustion, providing a safer environment for personnel and equipment during the hazards of fire

Compliances:

Industry:

- (UL) CMG-LS Listed E105765
- (UL) verified ANSI/TIA 568-C.2 Patch
- ISO/IEC 11801 Ed. 2.2
- Oil-Resistant per EN 50306-4

Flame Test:

- UL 1685 FT4 W/IEEE 1202 Limited Smoke
- IEC 60332-3-24
- ASTM E662 Smoke Emission
- BSS 7239 Combustion Toxicity
- IEC 61156-1

Other:

- NFPA-130 (2017) On-Vehicle
- RoHS and REACH Compliant



TRANSIT, 4 PAIR/24 AWG, SHIELDED FOIL TWISTED PAIR (SF/UTP) CAT 6, LOW-SMOKE, ZERO-HALOGEN

CATALOG NUMBER	# OF PAIRS	CONDUCTOR SIZE		NOM. COND. DIAMETER		NOM. INS. O.D.		NOM. JACKET THICKNESS		NOM. CABLE DIAMETER		NET CABLE WEIGHT	
		AWG	STRAND.	INCHES	mm	INCHES	mm	INCHES	mm	INCHES	mm	LBS/1000'	kg/km
443480	4	24	7/32	0.024	0.61	0.040	1.0	0.025	0.64	0.315	8.0	43.3	64.4

ELECTRICAL CHARACTERISTICS

FREQUENCY (MHz)	INSERTION LOSS (dB/100 m)	NEXT (dB)	ACRF (dB)	RL (dB)
	max.	min.	min.	min.
1	2.4	74.3	67.8	20.0
4	4.5	65.3	55.8	23.0
8	6.4	60.8	49.7	24.5
10	7.1	59.3	47.8	25.0
16	9.1	56.2	43.7	25.0
20	10.2	54.8	41.8	25.0
25	11.4	53.3	39.8	24.2
31.25	12.8	51.9	37.9	23.3
62.5	18.5	47.4	31.9	20.7
100	23.8	44.3	27.8	19.0
150	29.7	41.7	24.3	17.5
200	34.8	39.8	21.8	16.4
250	39.4	38.3	19.8	15.6
300	43.7	37.1	18.3	14.9
350	47.7	36.1	16.9	14.3

- DC Resistance:** 9.38 Ω /100 m Max.
- DCR Unbalanced:** 5% Max.
- Mutual Capacitance:** 5.6 nF/m Max.
- Capacitance Unbalanced:** 160 pF/100 m Max.
- Characteristic Impedance:** 100 Ω +/- 15 Ω
- Prop Delay (Skew):** 45 ns/100 m Max.
- Velocity of Propagation:** 72% Nom.
- Temperature:** Operation: -40°C to +75°C
Installation: 0°C to +60°C
- Bend Radius:** 4.7" Min.

Polyrad® XT Transit Databus Cables

Multi Vehicle Bus (MVB)/Wire Train Bus (WTB)

General Cable offers a wide variety of transit data communications cables that meet UL 1581 VW-1 flammability requirements, ASTM E662 smoke density, and Boeing BSS 7239 and Bombardier SMP 800-C toxicity standards. Transit data communications cables are produced in multi-conductors, coaxial, and shielded twisted pairs. Our high-quality products are engineered with outstanding thermal stability at elevated temperatures as well as excellent performance in sub-zero conditions. An extra-tough irradiated thermoset jacket provides resistance to most oils, chemicals, and moisture but still allows for flexibility and free stripping. General Cable also has the ability to design products specifically catered to individual customer needs and requirements.

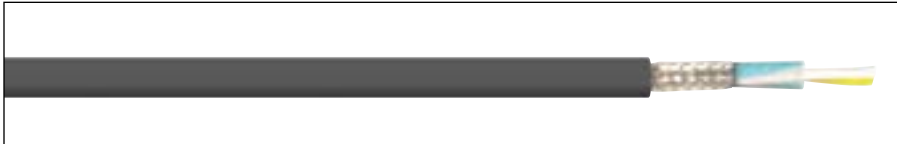

Product Construction:

Conductor:

- 20 AWG thru 12 AWG soft annealed tinned copper per ASTM B33, B8 and B172

Insulation:

- Low-smoke irradiated Cross-linked Polyolefin (XLPO)

Jacket

- Polyrad® XT flame-retardant, low-smoke irradiated Cross-linked Polyolefin (XLPO)

Print (Including but not limited to):

- GENERAL CABLE® (WC) POLYRAD® XT XX/COND XXAWG SHIELDED XXX OHM 110°C 600 V DAY/MONTH/YEAR

Options:

- Other data communications cables available upon request

Applications:

- Ideally suited for use where specific and stable electrical values are required
- Engineered and manufactured for both original equipment and retrofit use in electronic equipment

Features:

- Excellent flexibility and free stripping
- Outstanding thermal stability at elevated temperatures
- Excellent low-temperature performance; suitable for installation in sub-zero conditions
- Extra-tough, mechanically rugged irradiated thermoset jacket
- Resistant to most oils and chemicals

Compliances:

Flame Test:

- VW-1

Other:

- NFPA-130 (2017) On-Vehicle
- BSS 7239
- SMP 800-C
- ASTM E662
- RoHS and REACH Compliant

Packaging:

- Standard reel put-up

The data communications cables shown in the following tables are merely a sampling of General Cable's wide range of products. Other conductor sizes, designs and/or specific installation requirements are available to meet virtually all the cabling needs of the transit and locomotive industry. For more information, contact General Cable's Transit inside sales at info@generalcable.com.

100 OHM SHIELDED DATA CABLE

CATALOG NUMBER	AWG		NUMBER OF CONDUCTORS	INSULATED DIAMETER		JACKET THICKNESS		CABLE DIAMETER		NET CABLE WEIGHT	
	SIZE	STRANDING		INCHES	mm	MILS	mm	INCHES	mm	LBS/1000'	kg/km
387090	20	19/32	2	0.092	2.34	45	1.14	0.305	8.0	55	82

Shield: 36 AWG Tinned Copper Braid - 95% Minimum Coverage

Color Code: Yellow, White

387550	16	19/29	2	0.154	3.91	45	1.14	0.425	10.8	63	150
---------------	----	-------	---	-------	------	----	------	-------	------	----	-----

Shield: 36 AWG Tinned Copper Braid - 95% Minimum Coverage + Aluminum/Mylar Tape

Color Code: Yellow, White

120 OHM SHIELDED DATA CABLE

329960	20	19/32	2	0.114	2.90	45	1.14	0.342	8.7	62	92
---------------	----	-------	---	-------	------	----	------	-------	-----	----	----

Shield: 36 AWG Tinned Copper Braid - 90% Minimum Coverage

Color Code: Black, White

387540	18	19/30	2	0.173	4.40	45	1.14	0.460	11.7	99	147
---------------	----	-------	---	-------	------	----	------	-------	------	----	-----

Shield: 36 AWG Tinned Copper Braid - 95% Minimum Coverage + Aluminum/Mylar Tape

Color Code: Yellow, White

388500	18	19/30	3	0.173	4.40	45	1.14	0.470	11.9	83	124
---------------	----	-------	---	-------	------	----	------	-------	------	----	-----

Shield: Aluminum/Mylar Tape + 22 AWG 7/30 Tinned Copper Drain Wire

Color Code: White, Red, Green

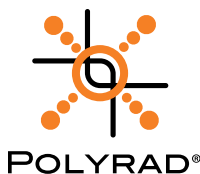

Transit Specialty Cables

3

SPECIFICATION NUMBER	PRODUCT DESCRIPTION	REVISION DATE	PAGE NUMBER
5310	Diesel Locomotive Cable 2000 Volts (EPR/XL-CPE) UL RHH/RHW-2, 2000 V and c(UL) RW90, 1000 V Flexible, Oil-, Sunlight- and Ozone-Resistant, Flame-Retardant, -40°C to 90°C	Sept. 2016	15
755	Electronically Controlled Pneumatic (ECP) Brake Cable 600 V, Two Conductor, Unarmored and Armored	Feb. 2019	16
760	TRANSPower Head-End Power Cable (HEP) Single Conductor, 4/0 AWG 1000 V or Three Conductor, 10 AWG 600 V	Oct. 2017	17

Diesel Locomotive Cable 2000 Volts (EPR/XL-CPE)

UL RHH/RHW-2 2000 V and c(UL) RW90, 1000 V

Flexible, Oil-, Sunlight- and Ozone-Resistant, Flame-Retardant, -40°C to 90°C

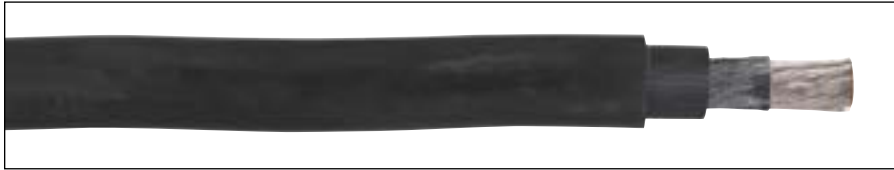

Compliances:

Industry Compliances:

- Type RHH/RHW-2 per UL 44, UL File # E90494
 - c(UL)US Type RW90 per CSA C.22.2-38, UL File # E90494
 - National Electrical Code (NEC)
 - ICEA S-95-658/NEMA WC70
 - "For CT Use" on 1/0 AWG and larger in accordance with NEC®
 - Accepted for listing as flame resistant by MSHA
 - RoHS Compliant
- Flame Test Compliances:**
- UL 2556 VW-1
 - IEEE 1202/CSA FT4 for sizes 1/0 AWG and larger

Product Construction:

Conductor:

- 14 AWG (2.08 mm) thru 1111.1 kcmil (562 mm) Class I fully annealed flexible stranded tin coated copper per AAR 589

Insulation:

- Flame-retardant, lead-free Cross-linked Ethylene Propylene (EP) with separator tape over the conductor to facilitate stripping

Jacket:

- Black, flame-retardant, sunlight-, ozone- and oil-resistant, lead-free Cross-linked Chlorinated Polyethylene (XL-CPE)
- Colors available upon request

Applications:

- For use up to 2000 V as power cables in wind turbine generator applications per UL Subject 6140
- Diesel electric locomotives

Applications (cont'd.):

- Mining and earth-moving equipment
- General purpose use as flexible power leads
- Flexible power leads in cable trays in sizes 1/0 AWG and larger
- Accepted for listing as flame-resistant by MSHA

Features:

- Rated 90°C wet or dry per UL 44/CSA C.22.2-38
- Flexible tinned copper stranding
- Excellent resistance to oils, gear lubricants, ozone, sunlight, heat and flame
- Designed to withstand continuous flexing

Minimum Bend Radius:

- 8X O.D. for fixed installations

Torsion Requirements:

- +/-180° twists per meter for 5,000 cycles at -40°C with cable weight compensated to 18 meters

AC Withstand Voltage Testing requirements per UL 44:

14 - 10 AWG	6000 V
8 - 2 AWG	7500 V
1 - 4/0 AWG	9000 V
262.6 kcmil - 444 kcmil	10000 V
535.3 kcmil - 929.9 kcmil	11000 V
1111.1 kcmil	13500 V

CATALOG NUMBER	COND. SIZE		COND. STRAND	NOMINAL COND. O.D.		NOM. INS. THICKNESS		JACKET THICKNESS		NOMINAL O.D.		APPROX. NET WEIGHT	
	AWG/kcmil	mm²		INCHES	mm	INCHES	mm	INCHES	mm	INCHES	mm	LBS/1000 FT	kg/km

14 AWG - 1111.1 kcmil CONDUCTORS

5310.01014	14	2.08	19W	0.070	1.8	0.045	1.1	0.015	0.4	0.20	5.1	30	45
5310.01012	12	3.31	19W	0.088	2.2	0.045	1.1	0.015	0.4	0.22	5.6	39	58
5310.01010	10	5.26	27W	0.117	3.0	0.045	1.1	0.015	0.4	0.25	6.4	56	83
5310.01008	8	8.36	37W	0.144	3.7	0.055	1.4	0.030	0.8	0.33	8.3	87	129
5310.01006	6	13.3	61W	0.190	4.8	0.060	1.5	0.030	0.8	0.38	9.7	131	195
5310.01004	4	21.1	105W	0.262	6.7	0.060	1.5	0.030	0.8	0.46	11.7	202	301
5310.01002	2	33.6	158W	0.315	8.0	0.060	1.5	0.030	0.8	0.51	13.0	285	424
5310.01001	1	42.4	224W	0.375	9.5	0.080	2.0	0.045	1.1	0.64	16.3	417	621
5310.01110	1/0	53.5	280W	0.435	11.0	0.080	2.0	0.045	1.1	0.70	17.8	494	735
5310.01210	2/0	67.4	329W	0.465	11.8	0.080	2.0	0.045	1.1	0.73	18.5	587	874
5310.01310	3/0	85	456W	0.535	13.6	0.080	2.0	0.045	1.1	0.80	20.3	718	1069
5310.01410	4/0	107	551W	0.581	14.8	0.080	2.0	0.045	1.1	0.84	21.3	845	1258
5310.01262	262.6	133	650W	0.617	15.7	0.090	2.3	0.065	1.7	0.94	23.9	1050	1563
5310.01313	313.1	158	777W	0.671	17.0	0.090	2.3	0.065	1.7	1.00	25.3	1195	1778
5310.01373	373.7	189	925W	0.735	18.7	0.090	2.3	0.065	1.7	1.06	26.9	1384	2060
5310.01444	444.4	225	1110W	0.786	20.0	0.090	2.3	0.065	1.7	1.11	28.2	1634	2432
5310.01535	535.3	271	1332W	0.877	22.3	0.090	2.3	0.065	1.7	1.20	30.5	1925	2865
5310.01646	646.4	327	1609W	0.960	24.4	0.090	2.3	0.065	1.7	1.29	32.8	2307	3433
5310.01777	777.7	394	1924W	1.054	26.8	0.090	2.3	0.065	1.7	1.38	35.1	2728	4060
5310.01929*	929.9	475	2318W	1.230	31.2	0.090	2.3	0.065	1.7	1.56	39.6	3570	5313
5310.01111*	1111.1	562	2745W	1.328	33.7	0.115	2.9	0.095	2.4	1.77	44.9	4232	6298

* Non-stock item; minimum runs apply. Please consult Customer Service for price and delivery.



Electronically Controlled Pneumatic (ECP) Brake Cable

600 V, Two Conductor, Unarmored and Armored

Product Construction:

Conductor:

- 8 AWG soft annealed tinned copper per ASTM B33

Insulation:

- Cross-linked Polyolefin (XLPO) - 125°C

Shield:

- 85% tinned copper braid shield with 16 AWG drain wire

Jacket:

- Arctic-grade, heavy-duty reinforced Cross-linked Chlorinated Polyethylene (XL-CPE)

Optional Armor:

- Galvanized steel (GSIA) and Aluminum (AIA)

Print:

- AAR ECP BRAKE CABLE S-4210 GENERAL CABLE® (WC) 2/C 8 AWG 600 V QUARTER/YEAR

Applications:

- Designed specifically for installation both under and between freight cars
- Meets all AAR specification S-4210 requirements

Features:

- 125°C rated Cross-linked Polyolefin (XLPO) insulation allows for routing through higher temperature areas. Insulation is also flexible and free stripping
- Tinned copper braided shield designed for significant EMI/RFI reduction
- Arctic-grade, heavy-duty reinforced Cross-linked Chlorinated Polyethylene (XL-CPE) jacket offers the lowest diameter for easier conduit pull and can be used in a ¾" conduit in lieu of 1". Excellent low-temperature performance suitable for installation in sub-zero conditions. Tough mechanical properties
- Optional galvanized or aluminum armor over the cable jacket allows for conduit-free installations providing significant installed cost savings
- Temperature range of -45°C to +100°C

Compliances:

Industry:

- AAR S-4210

Flame Test:

- IEEE 1202 (70,000 BTU/hr)
- IEEE 383 (70,000 BTU/hr)
- VW-1



ECP BRAKE CABLE

CATALOG NUMBER	NUMBER OF CONDUCTORS	CONDUCTOR (AWG) SIZE AND STRANDING		NOMINAL INSULATION THICKNESS		NOMINAL JACKET THICKNESS		NOMINAL CABLE DIAMETER		NET CABLE WEIGHT		AMPACITY (FREE AIR 40°C AMBIENT)
				MILS	mm	MILS	mm	INCHES	mm	LBS./1000'	kg/km	
443420	2	8	37/24	45	1.15	105	2.67	0.725	18.42	325	484	69
443440 (GSIA)	2	8	37/24	45	1.15	105	2.67	0.960	24.38	655	975	69

TRANSPOWER Head-End Power (HEP) Cables

Single Conductor, 4/0 AWG 1000 V or Three Conductor, 10 AWG 600 V



Product Construction

- Single Conductor:**
- 4/0 AWG 5320/34 Soft Bare Copper
- Insulation:**
- Chlorinated Polyethylene (CPE)
- Jacket:**
- Reinforced Chlorinated Polyethylene (CPE) – Black

- Ampacity:**
- 400 amps @ 30°C
- Print:**
- GENERAL CABLE® (LI) 1000 VOLT TRANSPOWER 4/0 AWG



Product Construction

- Three Conductors:**
- 10 AWG 259/34 Soft Tinned Copper
- Insulation:**
- Ethylene Propylene Diene Monomer (EPDM)
- Jacket:**
- Chlorinated Polyethylene (CPE) – Black

- Ampacity:**
- 40 amps @ 30°C
- Color Code:**
- Black, White, Red
- Print:**
- GENERAL CABLE® (LI) 600 VOLT TRANSPOWER 3/C 10 AWG

Applications:

- Head-End Power cable used in jumper assemblies locomotive-to-locomotive, locomotive-to-car and car-to-car for transmission of 480 V, 3 phase 50/60 Hz
- Designed for heavy-duty service where severe flexing is encountered

Features:

- 4/0 AWG is rated at 1000 V
- 10 AWG, 3 conductor is rated at 600 V
- Normal operating temperature -55°C to 90°C
- Jacket will not melt during 375°F molding operation
- Excellent flexibility; withstands continuous vibrations
- Outstanding resistance to moisture, oils and fluids, abrasion, tearing, compression, ozone, sunlight, flame and heat
- Minimum bend radius:
1/C 4/0 AWG: 7.2"
3/C 10 AWG: 5.5"

Industry Compliances:

- Amtrak Specification D-77-24
- Rope-Lay with bunch-stranded members per ASTM B172
- Soft annealed bare copper per ASTM B3
- Soft annealed tin copper per ASTM B33

TRANSPOWER HEAD-END POWER (HEP) CABLES

CATALOG NUMBER	NUMBER OF CONDUCTORS	CONDUCTOR (AWG) SIZE AND STRANDING		NOMINAL INSULATION THICKNESS		NOMINAL JACKET THICKNESS		NOMINAL CABLE DIAMETER		NET CABLE WEIGHT		AMPACITY (FREE AIR 30°C AMBIENT)
				MILS	mm	MILS	mm	INCHES	mm	LBS/1000'	kg/km	
87040	1	4/0	5320/34 SBC	60	1.52	85	2.16	0.900	22.86	961	1430	400*
87010	3	10	259/34 STC	45	1.14	95	2.41	0.685	17.40	314	467	40*

* Refer to NEC 310.15(B)(2) for the ampacity correction factors where the ambient temperature is other than 30°C (86°F).

Technical Information

4

SPECIFICATION NUMBER	PRODUCT DESCRIPTION	REVISION DATE	PAGE NUMBER
General Technical Information			
A100	Common Color Sequence	Oct. 2017	19
A125	Temperature Conversion Table	Oct. 2011	20
A150	Metric Conversion Factors	Sept. 2010	21
A186	AWG (American Wire Gauge) to mm ² (Millimeters Squared) Conversion	Oct. 2011	22
Conductor Data			
B041	Class I Conductors for General Wiring	Oct. 2017	23
B046	Class K Conductors for General Wiring	Oct. 2017	24
Handling and Storage Recommendations			
D001	Minimum Bend Radius	Oct. 2017	25
D005	Recommended Reel Handling Practices	May 2013	26
D025	Recommended Cable Handling Practices	Oct. 2011	27
D050	Recommended Cable Storage Practices	May 2013	28
Catalog Number Index			29

Common Color Sequence

Method 1 - Table E1 Color Sequence

COND. NO.	BACKGROUND OR BASE COLOR	FIRST TRACER COLOR	SECOND TRACER COLOR	COND. NO.	BACKGROUND OR BASE COLOR	FIRST TRACER COLOR	SECOND TRACER COLOR
1	Black	-	-	20	Red	Green	-
2	White	-	-	21	Orange	Green	-
3	Red	-	-	22	Black	White	Red
4	Green	-	-	23	White	Black	Red
5	Orange	-	-	24	Red	Black	White
6	Blue	-	-	25	Green	Black	White
7	White	Black	-	26	Orange	Black	White
8	Red	Black	-	27	Blue	Black	White
9	Green	Black	-	28	Black	Red	Green
10	Orange	Black	-	29	White	Red	Green
11	Blue	Black	-	30	Red	Black	Green
12	Black	White	-	31	Green	Black	Orange
13	Red	White	-	32	Orange	Black	Green
14	Green	White	-	33	Blue	White	Orange
15	Blue	White	-	34	Black	White	Orange
16	Black	Red	-	35	White	Red	Orange
17	White	Red	-	36	Orange	White	Blue
18	Orange	Red	-	37	White	Red	Blue
19	Blue	Red	-				

Pair cables are Black, White and numbered. Triad cables are Black, White, Red and numbered.

Method 4 - All Conductors Black

COND.	CONDUCTOR PRINTING
1st	"1-One"
2nd	"2-Two"
3rd	"3-Three"
4th	"4-Four"
5th	"5-Five"

Method 1 - Table E2 Color Sequence

COND. NO.	BACKGROUND OR BASE COLOR	TRACER COLOR	COND. NO.	BACKGROUND OR BASE COLOR	TRACER COLOR
1	Black	-	19	Orange	Blue
2	Red	-	20	Yellow	Blue
3	Blue	-	21	Brown	Blue
4	Orange	-	22	Black	Orange
5	Yellow	-	23	Red	Orange
6	Brown	-	24	Blue	Orange
7	Red	Black	25	Yellow	Orange
8	Blue	Black	26	Brown	Orange
9	Orange	Black	27	Black	Yellow
10	Yellow	Black	28	Red	Yellow
11	Brown	Black	29	Blue	Yellow
12	Black	Red	30	Orange	Yellow
13	Blue	Red	31	Brown	Yellow
14	Orange	Red	32	Black	Brown
15	Yellow	Red	33	Red	Brown
16	Brown	Red	34	Blue	Brown
17	Black	Blue	35	Orange	Brown
18	Red	Blue	36	Yellow	Brown

Pair cables are Black, Red and numbered. Triad cables are Black, Red, Blue and numbered. Colors repeat after 36 conductors. There are no Green or White conductors or stripes.

Temperature Conversion Table

Known temperature is in boldface type-**Temp (°F or °C)**. Corresponding temperature in degrees Fahrenheit will be found in the column to the right. Corresponding temperature in degrees Centigrade will be found in the column to the left.

-5 TO -100			0 TO 100						100 TO 500		
°C	Temp (°F or °C)	°F	°C	Temp (°F or °C)	°F	°C	Temp (°F or °C)	°F	°C	Temp (°F or °C)	°F
-73.3	-100	-148	-17.8	0	32.0	10.0	50	122.0	38	100	212
-70.5	-95	-139	-17.2	1	33.8	10.6	51	123.8	43	110	230
-67.8	-90	-130	-16.7	2	35.6	11.1	52	125.6	49	120	248
-65.0	-85	-121	-16.1	3	37.4	11.7	53	127.4	54	130	266
-62.2	-80	-112	-15.6	4	39.2	12.2	54	129.2	60	140	284
-59.5	-75	-103	-15.0	5	41.0	12.8	55	131.0	66	150	302
-56.7	-70	-94	-14.4	6	42.8	13.3	56	132.8	71	160	320
-53.9	-65	-85	-13.9	7	44.6	13.9	57	134.6	77	170	338
-51.1	-60	-76	-13.3	8	46.4	14.4	58	136.4	82	180	356
-48.3	-55	-67	-12.8	9	48.2	15.0	59	138.2	88	190	374
-45.6	-50	-58	-12.2	10	50.0	15.6	60	140.0	93	200	392
-42.8	-45	-49	-11.7	11	51.8	16.1	61	141.8	99	210	410
-40.0	-40	-40	-11.1	12	53.6	16.7	62	143.6	100	212	413
-37.2	-35	-31	-10.6	13	55.4	17.2	63	145.4	104	220	428
-34.4	-30	-22	-10.0	14	57.2	17.8	64	147.2	110	230	446
-31.6	-25	-13	-9.44	15	59.0	18.3	65	149.0	116	240	464
-28.9	-20	-4	-8.89	16	60.8	18.9	66	150.8	121	250	482
-26.1	-15	5	-8.33	17	62.6	19.4	67	152.6	127	260	500
-23.3	-10	14	-7.78	18	64.4	20.0	68	154.4	132	270	518
-20.5	-5	23	-7.22	19	66.2	20.6	69	156.2	138	280	536
			-6.67	20	68.0	21.1	70	158.0	143	290	554
			-6.11	21	69.8	21.7	71	159.8	149	300	572
			-5.56	22	71.6	22.2	72	161.6	154	310	590
			-5.00	23	73.4	22.8	73	163.4	160	320	608
			-4.44	24	75.2	23.3	74	165.2	166	330	626
			-3.89	25	77.0	23.9	75	167.0	171	340	644
			-3.33	26	78.8	24.4	76	168.8	177	350	662
			-2.78	27	80.6	25.0	77	170.6	182	360	680
			-2.22	28	82.4	25.6	78	172.4	188	370	698
			-1.67	29	84.2	26.1	79	174.2	193	380	716
			-1.11	30	86.0	26.7	80	176.0	199	390	734
			-0.56	31	87.7	27.2	81	177.8	204	400	752
			0	32	89.6	27.8	82	179.6	210	410	770
			0.56	33	91.4	28.3	83	181.4	216	420	788
			1.11	34	93.2	28.9	84	183.2	221	430	806
			1.67	35	95.0	29.4	85	185.0	227	440	824
			2.22	36	96.8	30.0	86	186.8	232	450	842
			2.78	37	98.6	30.6	87	188.6	238	460	860
			3.33	38	100.4	31.1	88	190.4	243	470	878
			3.89	39	102.2	31.7	89	192.2	249	480	896
			4.44	40	104.0	32.2	90	194.0	254	490	914
			5.00	41	105.8	32.8	91	195.8	260	500	932
			5.56	42	107.6	33.3	92	197.6			
			6.11	43	109.4	33.9	93	199.4			
			6.67	44	111.2	34.4	94	201.2			
			7.22	45	113.0	35.0	95	203.0			
			7.78	46	114.8	35.6	96	204.8			
			8.33	47	116.6	36.1	97	206.6			
			8.89	48	118.4	36.7	98	208.4			
			9.44	49	120.2	37.2	99	210.2			
						37.8	100	212.0			

Interpolation Factors

°C	Temp (°F or °C)	°F	°C	Temp (°F or °C)	°F	°C	Temp (°F or °C)	°F
0.56	1	1.8	2.22	4	7.2	3.89	7	12.6
1.11	2	3.6	2.78	5	9.0	4.44	8	14.4
1.67	3	5.4	3.33	6	10.8	5.00	9	16.2

Metric Conversion Factors

	To Convert From	To	Multiply By
Length	Inches	Millimeters	25.4
	Millimeters	Inches	0.03937
	Inches	Centimeters	2.54
	Centimeters	Inches	0.3937
	Feet	Meters	0.3048
	Meters	Feet	3.2808
Area	Kilofeet (1000 feet)	Kilometers	0.3048
	Kilometers	Kilofeet (1000 feet)	3.2808
	Square Inches	Square Millimeters	645.16
	Square Millimeters	Square Inches	0.00155
	Square Inches	Square Centimeters	6.4516
	Square Centimeters	Square Inches	0.155
Weight	Square Inches	Circular Mils	1,273,240
	Circular Mils	Square Inches	7.854×10^{-7}
	Circular Mils	Square Millimeters	5.066×10^4
	Square Millimeters	Circular Mils	1973.51
	Square Feet	Square Meters	0.0929
	Square Meters	Square Feet	10.764
Electrical	Pounds	Kilograms	0.4536
	Kilograms	Pounds	2.2046
	Pound/Kilofeet	Kilograms/Kilometer	1.4882
	Kilograms/Kilometer	Pounds/Kilofeet	0.6720
	Ohms/Kilofeet	Ohms/Kilometer	3.2808
	Ohms/Kilometer	Ohms/Kilofeet	0.3048
Mechanical	Microfarads/Kilofeet	Microfarads/Kilometer	3.2808
	Microfarads/Kilometer	Microfarads/Kilofeet	0.3048
	Insulation Resistance: Megohms— Kilofeet	Megohms— Kilometer	0.3048
	Megohms— Kilometer	Megohms— Kilofeet	3.2808
Mechanical	Pounds/Square Inch	Kilo Pascal*	6.895
	Kilo Pascal*	Pounds/Square Inch	0.1432
	Pounds (force)	Newtons	4.448

* 1 Pascal = 1 Newton/square meters

AWG (American Wire Gauge) to mm² (Millimeters Squared) Conversion

AWG/KCMIL	Circ. Mils ¹	Cross-Sectional Area (mm ²)
929	929,200	471
	789,410	400
777	777,700	394
750	750,000	380
646	646,400	327
600	600,000	304
	592,058	300
535	535,300	271
500	500,000	253
	473,646	240
444	444,400	225
400	400,000	203
373	373,700	187
	365,102	185
350	350,000	177
313	313,100	159
300	300,000	152
	296,029	150
262	262,600	133
250	250,000	127
	236,823	120
4/0	216,900	110
	187,485	95
3/0	174,800	89
	138,147	70

AWG/KCMIL	Circ. Mils ¹	Cross-Sectional Area (mm ²)
2/0	134,200	68
1/0	108,350	55
	98,676	50
1	87,295	44
	69,073	35
2	63,480	32
	49,338	25
4	42,080	21
	31,576	16
6	25,440	12.9
	19,735	10.0
8	15,730	8.0
	11,841	6.0
10	10,645	5.4
	7,894	4.0
12	6,309	3.2
	4,934	2.50
14	3,970	2.04
	2,960	1.50
16	2,503	1.31
	1,974	1.00
18	1,760	0.82
	1,480	0.75
20	1,118	0.52
	987	0.50

¹ Circular Mil Area values are approximate and are provided as a reference guide.

Class I Conductors for General Wiring

Copper Conductor

ASTM CLASS I

SIZE	STRANDING	NOMINAL AREA		NOMINAL DIAMETER		NOMINAL WEIGHT	
		CIRCULAR MILS	mm ²	INCHES	mm	LBS/KFT	kg/km
10	27/24	10,910	5.53	0.117	2.97	34	51
8	37/24	14,950	7.57	0.135	3.43	46	68
6	61/24	24,640	12.50	0.174	4.42	77	114
5	91/24	36,760	19	0.242	6.15	116	173
4	105/24	42,420	21	0.262	6.60	137	204
3	126/24	50,500	25	0.285	7.24	167	249
2	147/24	60,600	31	0.307	7.80	190	283
1	224/24	90,900	46	0.380	9.65	287	427
1/0	273/24	111,100	56	0.410	10.41	351	522
2/0	323/24	131,300	66	0.470	11.90	407	606
3/0	456/24	184,200	92	0.549	13.94	594	884
4/0	551/24	222,600	112	0.593	14.70	696	1035
262.6	646/24	261,000	133	0.630	16	820	1220
313.1	777/24	313,900	159	0.685	17.40	987	1469
373.7	925/24	373,700	189	0.750	19	1176	1750
444.4	1110/24	448,400	225	0.820	20.80	1413	2103
535.3	1332/24	538,100	271	0.895	22.70	1697	2525
592	1480/24	597,900	303	0.972	24.70	1858	2765
646.4	1591/24	642,800	327	0.980	24.90	2020	3006
777.7	1924/24	777,700	394	1.075	27.30	2435	3624
1111	2745/24	1,111,000	563	1.328	33.70	3400	5059

Dimensions and weights are nominal; subject to industry tolerances.

Class K Conductors for General Wiring

Copper Conductor

ASTM CLASS K

SIZE AWG/kcmil	STRANDING INCHES	NOMINAL AREA		NOMINAL DIAMETER		NOMINAL WEIGHT	
		CIRCULAR MILS	mm ²	INCHES	mm	LBS/KFT	kg/km
20	10/30	1,020	0.52	0.036	0.91	3.2	4.8
18	16/30	1,620	0.82	0.046	1.20	5	7.4
16	26/30	2,580	1.31	0.057	1.40	7.97	12
14	41/30	4,110	2.08	0.071	1.80	12.8	19
12	65/30	6,530	3.31	0.088	2.20	20.3	30.2
10	105/30	10,380	5.26	0.112	2.80	33.3	49.6
9	133/30	13,090	6.63	0.150	3.80	42.4	63.1
8	168/30	16,510	8.37	0.164	4	53.2	80.8
7	210/30	20,820	10.50	0.175	4.40	66.8	99.4
6	266/30	26,240	13.30	0.198	5.00	84.2	125
5	336/30	33,090	16.80	0.261	6.60	106	158
4	420/30	41,740	21.20	0.249	6.30	132	196
3	532/30	52,620	26.70	0.298	7.60	169	251
2	665/30	66,360	33.60	0.317	8.10	211	314
1	836/30	83,690	42.40	0.356	9	266	396
1/0	1045/30	104,500	53	0.400	10.2	333	496
2/0	1330/30	133,100	67.40	0.450	11.4	425	632
3/0	1672/30	167,800	85	0.525	13.3	535	796
4/0	2109/30	210,900	107	0.575	14.6	676	1006
250	2499/30	250,000	127	0.688	17	802	1193
262.6	2627/30	262,600	133	0.680	17	824	1226
300	2989/30	300,000	152	0.753	19	960	1428
313.1	3145/30	315,288	160	0.710	18	1002	1491
350	3458/30	350,000	177	0.818	21	1120	1667
373.7	3737/30	373,700	189	0.790	20	1210	1800
400	3990/30	400,000	203	0.878	22	1290	1920
444.4	4514/30	451,400	229	0.825	21	1415	2106
500	5054/30	500,000	253	0.990	25	1635	2433
535.3	5320/30	532,000	270	0.950	24	1732	2577
600	5985/30	600,000	340	1.125	29	1950	2902
646.4	6466/30	646,600	328	1.035	26	2058	3063
750	7448/30	750,000	380	1.276	32	2427	3611
1000	9975/30	1,000,000	507	1.498	38	3250	4769

Dimensions and weights are nominal; subject to industry tolerances.

Minimum Bend Radius

Standard Thermosetting (XLPO, Rubber) and Thermoplastic (PE, PVC, etc.) Insulated and Jacketed Single and Multi-Conductor Cables	Permanent Training After Installation (Static)	Pulling/Flexing (Dynamic)
a. Without Shield or Armor, O.D. Less Than 1.0"	4	10
b. Without Shield or Armor, O.D. Greater Than 1.0"	5	12
c. With Overall Braided Copper Shield	5	12
d. With Aluminum/Polyester Shield	5	12
e. With 26 AWG or Smaller Braided Steel or Alloy Armor	6	14
f. With Solid Overall Flat Metallic Copper Tape Shield	10	20
g. With Solid Overall Flat Metallic Tape Armor	12	24
h. With Interlocked Armor ("S" Profile)	7	14
i. With Components Individually Shielded with Copper Braids or Laminated Copper or Aluminum/Polyester Tapes	5	12
j. With Corrugated Armor or Shield Tape	8	16
k. Coax & Triax	4	20

Multiply the ratio in this table times the nominal (calculated) overall cable diameter to obtain the minimum bending radius.

Recommended Reel Handling Practices

How to Handle Cable Reels

YES

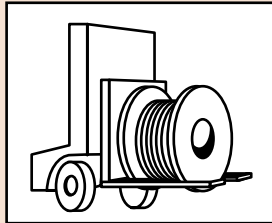

Cradle both reel flanges between forks.

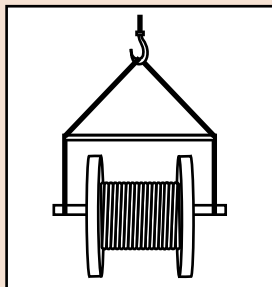

Reels can be hoisted with a shaft extended through both flanges.

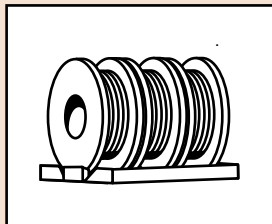

Always load with flanges on edge and chock and block securely.

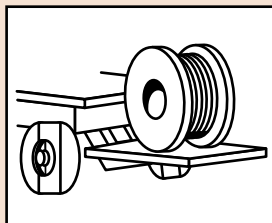

Lower reels from truck using hydraulic gate, hoist or fork lift. **LOWER CAREFULLY.**

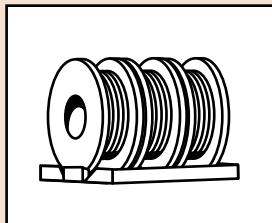

Always load with flanges on edge and chock and block securely.

NO

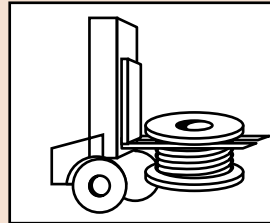

Do not lift by top flange. Cable or reel will be damaged.

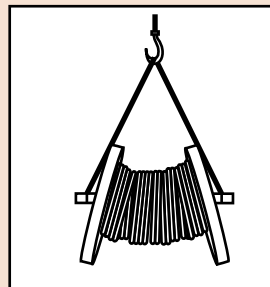

Use a spreader bar to prevent bending the reel flanges and mashing the cable.

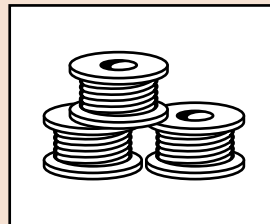

Upended heavy reels will often arrive damaged. Refuse or receive subject to inspection for hidden damage.

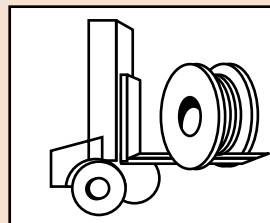

Never allow forks to touch cable surface or reel wrap.

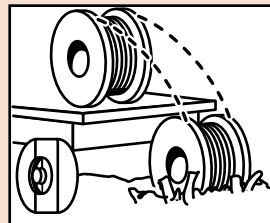

Never drop reels.

Recommended Cable Handling Practices

Unloading and Moving of Reels:

Cable reels are never shipped upended (flat side down). Cable reels that arrive in this manner should be rejected or received only after a thorough inspection for damage.

See “Recommended Reel Handling Practices” page.

Upon receipt, a cable’s protective covering and/or lagging should be inspected for evidence of damage during shipment. If evidence of damage is found, a report should immediately be made to the carrier.

Under no circumstances should reels be dropped from the delivering vehicle to the ground.

Unloading and reel handling should be accomplished so that the equipment used does not contact the cable surface, and in the case of protective wrap, that the equipment does not contact the protective wrap.

If unloading and reel handling is accomplished by crane, either a cradle supporting the reel flanges or a shaft through the arbor hole should be used. If a fork lift is utilized, the forks must lift the reel at 90° to the flanges and the forks must be long enough to make complete lifting contact with both flanges. Under no circumstances should the forks come into contact with the cable surface or the protective wraps.

When a reel of cable is rolled from one point to another, care must be taken to see that there are no objects on the surface area which could contact or damage the cable surface or protective wrap.

If an inclined ramp is used for unloading, the ramp must be wide enough to contact both flanges completely. The stopping of the reels at the bottom shall be accomplished by using the reel flanges and not the surface of the cable.

Minimum Drum Diameters for Packaging Cables	
Type of Cable	Minimum Drum Diameter as a Multiple of Outside Diameter of Cable
1. Single and multiple conductor cable - unshielded 0-2000 V	10
2. Single and multiple conductor cable - unshielded 2400 V	12
3. Single and multiple conductor cable - wire shield (UniShield [®]) 5-35 kV	12
4. Single and multiple conductor cable - helically applied tape shield (Uniblend [®]) 5-35 kV	14
5. Single and multiple conductor cable - longitudinally applied flat tape shield (Type TC)	20
6. Single and multiple conductor cable - Interlocked Armor (Duralox [®]) 600 V-35 kV	14
7. Triplexed single conductors cabled together. The circumscribing overall diameter* shall be multiplied by the factor in 1 - 6 and then by the reduction factor.	.75

*Single conductor times 2.155 times
NEMA WC26 EEMAC201-2007 Binational Wire and Cable Packaging Standard

Recommended Cable Storage Practices

Storage and Storage Maintenance:

Finished cables have no established shelf-life. Moisture and atmospheric conditions can cause exposed conductors to oxidize and discolor. Uncovered/unsheltered cable will degrade due to exposure to direct sunlight and/or the elements. If the cables are protected, there should be no degradation of the insulation.

In general, any cable for use indoors should be stored indoors. Any cable suitable for installation outdoors is suitable for storage outdoors. Cables stored outdoors should have the ends sealed to prevent moisture ingress into the cable and should be used within two years or less.

Cables should be stored in a sheltered area. The cable conductor should not be exposed to water.

Cables with a cold temperature marking, e.g. -10°C , -25°C , or -40°C , may be stored outdoors. Cables without a cold temperature marking must be stored indoors.

Cable reels must remain in the upright position. Cable reels must not be stored on their sides. Reels must not be stacked.

Cable reels should be stored with the protective covering or lagging in place. If a length of cable has been cut from the reel, the cable end should be immediately resealed to prevent the entrance of moisture. If a part length is returned to storage, the reel's protective covering should be restored.

Wooden reels should be stored off the ground to prevent rotting. Reels should be stored on a flat, hard surface so that flanges do not sink into the earth. The weight of the reel and cable must be carried at all times by the reel flanges.

Cable reels and lagging must not be stored for an extended time period sitting in direct contact with water or dampness. Timbers or metal supports must be placed under the reel flanges to provide elevated storage of the reels away from the direct contact with water or damp soil.

Reels should be stored in an area where construction equipment, falling or flying objects or other materials will not contact the cable.

Cable should be stored in an area where chemicals or petroleum products will not be spilled or sprayed on the cable.

Cable should be stored in an area away from open fires or sources of high heat.

If the reels are relocated, they should be handled as suggested in the "Recommended Reel Handling Practices" section, and inspection made on each reel during the relocation.

If the cables are stored in a secure area and not exposed to the effects of the weather, an annual inspection should be satisfactory.

Where the reels are exposed to the weather, a bimonthly inspection should be performed to observe any sign of deterioration.

If the reels are exposed in a non-secure area, policing of the area at frequent intervals may be required depending on circumstances.

Records of delivery date, manufacturer, installation date, any extenuating circumstances, along with all test reports, should be kept on file.

Catalog Number Index

CATALOG NUMBER	PAGE	CATALOG NUMBER	PAGE	CATALOG NUMBER	PAGE	CATALOG NUMBER	PAGE
5310.01001	15	303910	2	369600	5	390240	8
5310.01002	15	304020	3	369610	5	390250	8
5310.01004	15	315130	2	373750	4	390260	8
5310.01006	15	318420	2	373760	4	390270	8
5310.01008	15	324680	4	373770	4	390280	8
5310.01010	15	325290	3	373780	4	390290	8
5310.01012	15	329960	13	374360	4	390300	8
5310.01014	15	330230	2	376760	4	390310	8
5310.01110	15	355320	2	387070	4	390320	8
5310.01111	15	355330	2	387090	13	390500	8
5310.01210	15	355340	2	387460	4	398600	6
5310.01262	15	355350	2	387540	13	398610	6
5310.01310	15	355360	2	387550	13	398620	6
5310.01313	15	355370	2	387570	4	398630	6
5310.01373	15	355380	2	387710	6	398640	6
5310.01410	15	355390	2	387730	6	398650	6
5310.01444	15	355400	2	388500	13	398730	6
5310.01535	15	355410	2	389730	8	398740	6
5310.01646	15	355420	2	389740	7	398750	6
5310.01777	15	355430	2	389750	8	398760	6
5310.01929	15	355440	2	389980	7	398770	6
87010	17	355450	2	389990	7	398780	6
87040	17	355460	2	390000	7	412170	4
260080	3	355470	2	390010	7	412180	4
263400	3	355480	2	390020	7	412190	4
267040	3	355490	3	390030	7	412200	4
269970	3	355500	3	390040	7	412210	4
280700	2	355510	3	390050	7	418460	6
280710	2	355520	3	390060	7	418510	6
280720	2	355530	3	390070	7	418530	6
280740	3	355540	3	390080	7	443230	10
296420	2	355550	3	390090	7	443240	11
296490	2	355560	3	390100	7	443360	6
296500	3	355570	3	390110	7	443370	6
296510	3	355580	3	390120	7	443380	6
296520	3	355590	3	390130	7	443390	6
297970	3	355600	3	390140	8	443420	16
300180	3	355610	3	390150	8	443440	16
300620	3	355620	3	390160	8	443480	12
300890	3	355630	3	390170	8		
300900	3	364980	3	390180	8		
301260	3	369550	5	390190	8		
301270	3	369560	5	390200	8		
301280	3	369570	5	390210	8		
302440	3	369580	5	390220	8		
303480	3	369590	5	390230	8		

CONSTRUCTION



Markets:
Commercial, Residential, Institutional

Products:
Building Wire (Al & Cu), Portable Cord, Industrial Cable

ENERGY



Markets:
Transmission, Distribution, Generation

Products:
Underground Cable, Substation Cable, Overhead Conductor & Cable

ENTERPRISE & COMMUNICATIONS



Markets:
Commercial/Residential Buildings, Data Centers, Education, Finance, Federal/Government, Healthcare, AV, Manufacturing

Products:
Datacom Cable, Fiber Optic Cable, Electronics Cable, Telecommunications Cable

INDUSTRIAL



Markets:
Petrochemical, Food & Beverage, Automation, Water/Wastewater, Power Generation, Pulp & Paper

Products:
Portable & Temporary Power Cord, Instrumentation Cable, Control Cable, Power Cable, Automation Cable

MILITARY



Markets:
On Land, At Sea, In the Air

Products:
Communications Wire & Cable (Cu & Fiber), Shore to Ship Power Cable, Wire Harnesses & Assemblies

MINING



Markets:
Surface, Underground

Products:
Portable & Trailing Mining Cable, Mine Power Feeder Cable, Industrial Cable

RENEWABLE ENERGY



Markets:
Solar, Hydro, Wind

Products:
Panel Wire, Cu & Al PV Wire, Tower Wire & Cable, Collection System Cable, Industrial Cable, Utility Cable

OIL, GAS & PETROCHEMICAL



Markets:
Upstream, Downstream, Midstream

Products:
Offshore Cable, Subsea Cable, Onshore Cable

TELCO



Markets:
Independent Telephone Operating Companies (ITOCs), Regional Bell Operating Companies (RBOCs)

Products:
Air Core Cable, Filled Core Cable, Wire Products, Central Office Cable

TRANSPORTATION



Markets:
Automotive, Agricultural Equipment, Rail & Transit, Heavy Duty & Industrial Trucks, Bus

Products:
On-Vehicle Data Communications, Control & Power Wire and Cable, Battery Cable, Primary Wire, Electric Vehicle (EV) Products, Wire Harnesses and Assemblies

General Cable

4 Tesseneer Drive
Highland Heights, Kentucky 41076-9753
Telephone: 866.248.7060
859.572.8000
Email: info@generalcable.com
www.generalcable.com

156 Parkshore Drive
Brampton, Ontario L6T 5M1
Telephone: 800.561.0649
905.494.5300
Fax: 800.565.2529
Email: info@generalcable.com